

HP VISUALIZE B Class and C Class Owner's Guide

HP VISUALIZE Workstation

Printed in USA



Manufacturing Part Number: HP Part No. A5992-90000

Edition E1299

Notice

UNIX is a registered trademark in the United States and other countries, licensed exclusively through X/Open Company Limited.

The information contained in this document is subject to change without notice.

Hewlett-Packard assumes no responsibility for the use or reliability of its software on equipment that is not furnished by Hewlett-Packard.

This document contains proprietary information that is protected by copyright. All rights reserved. No part of this document may be photocopied, reproduced or translated to another language without the prior written consent of Hewlett-Packard Company.

HEWLETT-PACKARD WARRANTY STATEMENT

HP PRODUCT

DURATION OF WARRANTY

HP VISUALIZE B Class and C Class Computers

1 Year

1. HP warrants HP hardware, accessories and supplies against defects in materials and workmanship for the period specified above. If HP receives notice of such defects during the warranty period, HP will, at its option, either repair or replace products which prove to be defective. Replacement products may be either new or like-new.
2. HP warrants that HP software will not fail to execute its programming instructions, for the period specified above, due to defects in material and workmanship when properly installed and used. If HP receives notice of such defects during the warranty period, HP will replace software media which does not execute its programming instructions due to such defects.

3. HP does not warrant that the operation of HP products will be uninterrupted or error free. If HP is unable, within a reasonable time, to repair or replace any product to a condition as warranted, the customer will be entitled to a refund of the purchase price upon prompt return of the product.
4. HP products may contain remanufactured parts equivalent to new in performance or may have been subject to incidental use.
5. The warranty period begins on the date of delivery or on the date of installation if installed by HP. If customer schedules installation or causes installation by HP to be delayed more than 30 days after delivery, warranty begins on the 31st day from delivery.
6. Warranty does not apply to defects resulting from (a) improper or inadequate maintenance or calibration, (b) software, interfacing, parts or supplies not supplied by HP, (c) unauthorized modification or misuse, (d) operation outside of the published environmental specifications for the product, or (e) improper site preparation or maintenance.
7. TO THE EXTENT ALLOWED BY LOCAL LAW, THE ABOVE WARRANTIES ARE EXCLUSIVE AND NO OTHER WARRANTY OR CONDITION, WHETHER WRITTEN OR ORAL, IS EXPRESSED OR IMPLIED AND HP SPECIFICALLY DISCLAIMS ANY IMPLIED WARRANTIES OR CONDITIONS OF MERCHANTABILITY, SATISFACTORY QUALITY, AND FITNESS FOR A PARTICULAR PURPOSE.
8. HP will be liable for damage to tangible property per incident up to the greater of \$300,000 or the actual amount paid for the product that is the subject of the claim, and for damages for bodily injury or death, to the extent that all such damages are determined by a court of competent jurisdiction to have been directly caused by a defective HP product.
9. TO THE EXTENT ALLOWED BY LOCAL LAW, THE REMEDIES IN THIS WARRANTY STATEMENT ARE CUSTOMER'S SOLE AND EXCLUSIVE REMEDIES. EXCEPT AS INDICATED ABOVE, IN NO EVENT WILL HP OR ITS SUPPLIERS BE LIABLE FOR LOSS OF DATA OR FOR DIRECT, SPECIAL, INCIDENTAL, CONSEQUENTIAL (INCLUDING LOST PROFIT OR DATA), OR OTHER DAMAGE, WHETHER BASED IN CONTRACT, TORT, OR OTHERWISE.

FOR CONSUMER TRANSACTIONS IN AUSTRALIA AND NEW ZEALAND: THE WARRANTY TERMS CONTAINED IN THIS STATEMENT, EXCEPT TO THE EXTENT LAWFULLY PERMITTED, DO NOT EXCLUDE, RESTRICT OR MODIFY AND ARE IN ADDITION TO THE MANDATORY STATUTORY RIGHTS APPLICABLE TO THE SALE OF THIS PRODUCT TO YOU.

RESTRICTED RIGHTS LEGEND. Use, duplication, or disclosure by the U.S. government is subject to restrictions as set forth in subdivision (c) (1) (ii) of the Rights in Technical Data and Computer Software Clause in DFARS 252.227.7013. Hewlett-Packard Co., 3000 Hanover St., Palo Alto, CA 94304.

Contents

1. System Overview

Product Description	23
System Unit Front Panel and Removable Devices	26
System LCD	27
System Power Switch	27
Removable Media Devices	28
System Unit Rear Panel Connectors	29
Audio Connectors	31
USB Connectors	32
HP Parallel I/O Connector	33
802.3 Network Connectors	33
RS-232C Serial Input/Output Connector	34
SCSI Connectors	35
Power Cord Connector	35
Security Loop	36
Locking Your System Unit's Left-Side Panel	37
Memory	38
Monitors	39
Operating System Overview	40
Information You Need to Record	41
LAN Station ID	41
IP Address and Subnetwork Mask Information	41
Powering Up Your System	42
Getting Required Information	43
Turning on the Power	45
Documentation	46

2. Using Your CD Drive

Contents

CD Media Description	49
Caring for CDs.	49
Operating the CD Drive.	50
CD Drive	50
Loading and Unloading a CD.	52
Locating Help	54
Mounting and Unmounting a CD	55
Mounting a CD Using SAM	55
Unmounting a CD Using SAM.	58
Verifying the CD Drive Operation.	61
Configuring the CD Driver	62
Audio Control for the CD Drive.	63
Installing the xgcd Utility.	63
Using the xgcd Utility	64
3. Using Your 3.5-Inch Floppy Disk Drive	
Operating the Floppy Drive.	69
Floppy Disk Drive	69
Using the Floppy Diskette	70
Using Device Files.	71
Formatting a New Diskette	74
Transferring Data To and From a Floppy Diskette	75
Listing the Files on a Floppy Diskette.	76
Troubleshooting.	76
Verifying the Floppy Drive Configuration.	77
Additional Floppy Drive Information	78
Configuring the Floppy Driver	78
For More Information	78

Contents

4. SCSI Connections

SCSI Bus Differences	83
SCSI Restrictions.....	84
Cables	84
Terminators	86
Number of Devices Per SCSI Bus	86
Considerations for Selecting SCSI Devices.....	86
SCSI Bus Length Constraints.....	88
Ultra Narrow Single-Ended SCSI Bus Length.....	88
Ultra2 Wide Low-Voltage Differential SCSI Bus Length.....	89
Assigning SCSI Device IDs.....	90
Assigning Ultra Narrow Single-Ended SCSI Device IDs.....	91
Assigning Ultra2 Wide Low-Voltage Differential SCSI Device IDs ..	92
Connecting to the SCSI Ports	93
System SCSI Port Connection	93

5. Changing Your Computer Hardware Configuration

System Unit Front Panel.....	98
Opening the System Unit Front Panel	98
Closing the System Unit Front Panel	99
Left Side Panel of the System Unit	100
Opening the Left Side Panel of the System Unit	100
Closing the Left Side Panel of the System Unit	102
System Unit Power Supply	103
Propping Up the Power Supply	103
I/O Cards	106
Removing I/O Cards.....	107
Installing I/O Cards	109

Contents

System Unit Fans	110
Removing the Fan from the Hard Disk Drive Area	111
Replacing the Hard Disk Drive Fan	113
Removable Media Devices	114
Installing a CD Drive	114
Removing a CD Drive	120
Installing a Floppy Disk Drive	126
Removing a Floppy Disk Drive	133
Hard Disk Drives	140
Installing a Hard Disk Drive	141
Removing a Hard Disk Drive	144
Configuring a Hard Disk Drive as a File System	148
Memory Cards	153
Installing Additional Memory	153
Removing Memory	157
Changing Your Monitor Type	159
Setting the Monitor Type at Power On	159
Setting the Monitor Type from the Boot Console Interface	159
Setting the Monitor Type Using SAM	160
Troubleshooting Monitor Problems	163
6. The Boot Console Interface	
Boot Console Interface Features	167
Accessing the Boot Console Interface	172
Booting Your Computer	174
Searching for Bootable Media	177
Resetting Your Computer	178
Displaying and Setting Paths	179

Contents

Displaying and Setting the Monitor Type	181
The Monitor Command	181
Displaying the Current Monitor Configuration	183
Setting the Monitor Type	184
Setting the Monitor Type with SAM	185
Setting the Monitor Type at Power On	188
Troubleshooting Monitor Problems	189
Changing the Console to an External Terminal	190
Displaying the Current Memory Configuration	191
Memory Information Sample	192
Displaying the Status of the System I/O	193
Setting the Auto Boot and Auto Search Flags	194
Displaying and Setting the Security Mode	196
Displaying and Setting the Fastboot Mode	197
Displaying the LAN Station Address	198
Displaying System Information	199
7. Solving Problems	
Common Problems and Solutions	203
Dealing with a Boot Failure	207
Memory Failures	209
LCD Information	210
LCD Fan Failures and Warnings	211
Troubleshooting Monitor Problems	213
Running System Verification Tests	214
A. Safety and Regulatory Statements	

Contents

Declaration of Conformity	217
Emissions Regulations	218
For FCC B Applications:	218
EMI Class A RRL (Korea)	219
VCCI Class B ITE (Japan)	219
EMI Class A (Taiwan)	220
Special Video Configuration Statement	220
Third Party Emissions Regulations Compliance	221
Special Regulatory and Safety Information	222
Acoustics	222
Laser Safety Statement (U.S.A. Only)	222
LEDs	222
Warnings and Cautions	223
WARNING:	223
WARNUNG:	223
AVERTISSEMENT:	223
WARNING:	223
WARNUNG:	223
ADVERTISSEMENT:	223

Glossary

Figures

Figure 1-1. System Unit Front Panel Controls	26
Figure 1-2. LCD Symbols HP Visualize B Class and C Class Features .	27
Figure 1-3. System Unit Rear Panel Connectors	30
Figure 1-4. Audio Connectors	31
Figure 1-5. Security Loop Components	36
Figure 1-6. Closed Left-Side Panel	37
Figure 2-1. CD Drive Controls and Features	51
Figure 2-2. Open CD Tray	52
Figure 2-3. Placing the CD in the Disk Tray	53
Figure 2-4. Closed Disk Tray	53
Figure 3-1. Floppy Disk Drive Controls and Features	69
Figure 3-2. Setting the Write-Protect Tab on a Floppy Diskette	70
Figure 3-3. Inserting and Removing a Floppy Diskette	71
Figure 5-1. Opening the Front Panel	98
Figure 5-2. Opening the Left Side Panel of the System Unit	101
Figure 5-3. Unscrewing the Power Supply Captive Screws	103
Figure 5-4. Propping Up the Power Supply	104
Figure 5-5. PCI Card Slot Numbering and Capabilities	106
Figure 5-6. I/O Slot Numbering	107
Figure 5-7. Removing the I/O Card Retainer	108
Figure 5-8. Removing the I/O Card	108
Figure 5-9. Fan Cooling Areas for the System Unit	110
Figure 5-10. Removing the Fan from the Hard Disk Drive Chassis . . .	112

Figures

Figure 5-11. Removing the CD Drive Bay's Rear Cover	115
Figure 5-12. Front of System Unit with the Front Panel Removed. . .	115
Figure 5-13. Removing the CD Drive Bracket and Blank	116
Figure 5-14. Installing the CD Drive	117
Figure 5-15. Plugging in the Audio, ATAPI and Power Cables	118
Figure 5-16. Tightening the Bracket Screws	118
Figure 5-17. Replacing the CD Drive Bay's Rear Cover.	119
Figure 5-18. Removing the CD Drive Bay's Rear Cover	121
Figure 5-19. Front of the System Unit with the Front Panel Removed	122
Figure 5-20. Removing the CD Drive	123
Figure 5-21. Installing the CD Drive Blank	124
Figure 5-22. Tightening the Bracket Screws	125
Figure 5-23. Replacing the CD Drive Bay's Rear Cover.	125
Figure 5-24. Removing the Floppy Disk Drive Bay's Rear Cover	127
Figure 5-25. Front of System Unit with the Front Panel Removed. . .	128
Figure 5-26. Removing the Floppy Disk Bracket and Blank	129
Figure 5-27. Installing the Floppy Disk Drive	130
Figure 5-28. Plugging In the Floppy Data and Power Cables	131
Figure 5-29. Tightening the Bracket Screws	131
Figure 5-30. Replacing the Floppy Disk Drive Bay's Rear Cover	132
Figure 5-31. Removing the Floppy Disk Drive Bay's Rear Cover	134
Figure 5-32. Front of System Unit with the Front Panel Removed. . .	135
Figure 5-33. Removing the Floppy Disk Drive	136

Figures

Figure 5-34. Installing the Floppy Disk Blank and Bracket	137
Figure 5-35. Tightening the Bracket Screws	138
Figure 5-36. Replacing the Rear Floppy Disk Drive Bay's Cover	138
Figure 5-37. The Hard Drive Slots	141
Figure 5-38. Removing the Hard Drive Bracket	142
Figure 5-39. Inserting the Hard Disk Drive	143
Figure 5-40. The Hard Drive Slots	144
Figure 5-41. Removing the Hard Disk Drive	145
Figure 5-42. Removing the Hard Disk Drive from Its Bracket	146
Figure 5-43. Replacing the Hard Disk Drive Bracket	147
Figure 5-44. Propping Up the Power Supply	154
Figure 5-45. Memory Card Slot Numbers and Loading Sequence	155
Figure 5-46. Installing Memory Cards	156
Figure 5-47. Propping Up the Power Supply	157
Figure 5-48. Removing Memory Cards	158
Figure 7-1. Fan Locations	212

Figures

Tables

Table 1-1. HP Visualize B Class and C Class Features	23
Table 1-2. Audio Electrical Specifications	32
Table 1-3. Serial I/O Pins	34
Table 2-1. CD Drive Operating Controls and Features	51
Table 3-1. Floppy Disk Drive Operating Controls and Features	69
Table 4-1. SCSI Bus Differences	83
Table 4-2. Ultra Narrow Single-Ended SCSI Cables	84
Table 4-3. Ultra2 Wide Low-Voltage Differential SCSI Cables	85
Table 6-1. System Paths	179
Table 6-2. Mnemonic Style Notation for Boot Paths	179
Table 7-1. Problems Powering Up the System	203
Table 7-2. Problems Loading and Booting the Operating System	204
Table 7-3. Problems with the 802.3 Network	204
Table 7-4. Problems Using a Hard Disk Drive	205
Table 7-5. Problems Using the CD Drive	205
Table 7-6. Problems Using the Floppy Disk Drive	206
Table 7-7. Fan Numbers and Their Names	211
Table A-1. Regulation On Noise Declaration For Machines -3. GSGV	222

Tables

Preface

This owner's guide describes how to use your HP VISUALIZE B Class and C Class computer.

This manual assumes that you have installed your computer as described in the *HP VISUALIZE B Class and C Class Installation Card*.

Audience

This guide is intended for HP VISUALIZE B Class and C Class computer users.

Safety and Regulatory Statements

See Appendix A for the safety and regulatory statements that apply to the HP VISUALIZE B Class and C Class computer.

Installation Notice

Products designated in the applicable Hewlett-Packard price list as customer-installable can be installed by computer-knowledgeable customers who carefully read and follow the instructions provided. Customers who elect to have the product installed by our field personnel are charged the applicable field installation charge, as covered under the standard terms and conditions. For more information, please contact your local sales representative.

Related Manuals

For more information, refer to the following documents:

- *Configuring HP-UX for Peripherals*
- *HP-UX System Administration Tasks*
- *HP CDE Getting Started Guide*
- *Managing Systems and Workstations*
- *Using HP-UX.*
- *Using Your HP Workstation*

Note that the documents listed above can be viewed with a web browser using this URL:

<http://www.docs.hp.com>

Revision History

The revision history for each edition of the manual is listed below:

Edition	Revision History
E0299	First Printing

Problems, Questions, and Suggestions

If you have any problems or questions with our hardware, software, or documentation, please contact either your HP Response Center or your local HP representative. If you have access to a web browser, you can get the latest software and hardware patches at the following URL:

<http://us-support.external.hp.com/>

Documentation Conventions

Unless otherwise noted in the text, this guide uses the following symbolic conventions.

<i>user-supplied values</i>	Italic words or characters in syntax and command descriptions represent values that you must supply. Italics are also used in text for emphasis.
screen display	Information that the system displays, commands that you must use literally, and path names appear in this typeface.
Enter	Keycaps are presented with a special keycap font as shown in the left column. (In this document, we refer to the Enter key. On your keyboard, the key may be labeled either Enter or Return .)

Electrostatic Discharge (ESD) Precautions

Electrostatic charges can damage the integrated circuits on printed circuit boards. To prevent such damage from occurring, observe the following precautions during board unpacking and installation:

- Stand on a static-free mat.
- Wear a static strap to ensure that any accumulated electrostatic charge is discharged from your body to ground.
- Create a common ground for the equipment you are working on by connecting the static-free mat, static strap, routing nodes, and peripheral units to that piece of equipment.
- Keep uninstalled printed circuit boards in their protective antistatic bags.
- Handle printed circuit boards by their edges, once you have removed them from their protective antistatic bags.

1 **System Overview**

This chapter introduces the HP VISUALIZE B Class and C Class computer. Its purpose is to familiarize you with your computer and its controls and indicators.

Instructions in this chapter assume that you are using the HP-UX 10.20 or 11.0 operating system with the HP CDE interface. Note that the HP-UX 10.20 or 11.0 operating system is a Year 2000 compliant operating system.

The topics included in this chapter are:

- Product Description
- System Unit Front Panel and Removable Devices
- System Unit Rear Panel Connectors
- Monitors
- Operating System Overview
- Information You Need to Record
- Powering Up Your System.

Product Description

To help you gain a better understanding of the HP VISUALIZE B Class and C Class computer, Table 1-1 provides the computer's key features.

Table 1-1 HP VISUALIZE B Class and C Class Features

Computer Feature	Description
Processor	PA8500 with operating frequencies of 300MHz for the B1000 and 400MHz for the C3000. This processor has a 0.5Mbyte instruction cache and a 1.0Mbyte data cache.
Operating System	HP-UX 10.20 HP-UX 11.0
User Interface	HP CDE graphical user interface
Compatibility	Source and binary code compatible with the B and C Class product family
Monitors	List of compatible monitors: <ul style="list-style-type: none"> • 19 inch, 1280x1024 and 1600x1200 color, 75Hz • 21 inch, 1280x1024 (stereo capability) and 1600x1200 color, 75Hz • 18" Flat Screen Display
Optional Graphics	Supported graphics devices: <ul style="list-style-type: none"> • HP VISUALIZE-EG and VISUALIZE-fx^2 Pro (for B1000) • HP VISUALIZE-EG, VISUALIZE-fx^2 Pro and VISUALIZE-fx^4 Pro (for C3000) • HP VISUALIZE Fe

Table 1-1 HP VISUALIZE B Class and C Class Features

Computer Feature	Description
Main Memory	The B1000 and C3000 computers use 128 MByte and 256 MByte DIMMs to provide a minimum of 128 MBytes and a maximum of 2GBytes of memory. These computers each have eight memory slots.
Internal Storage Devices	Ultra2 Wide Low-Voltage Differential (LVD) SCSI hard disk drive(s) and a choice of either a floppy disk drive or CD drive or both.
Standard Network	RJ45, Twisted Pair 10 BaseT/100 BaseT
Standard I/O	<p>Standard computer I/O ports:</p> <ul style="list-style-type: none"> • Ultra2 Wide Low-Voltage Differential (LVD) SCSI, one • Ultra Narrow Single-Ended (NSE) SCSI, one • Parallel port (IEEE 1284), one • Universal Serial Bus (USB) ports, two • Serial interface ports (RS-232C), two • Audio ports (Line in, line out, headset, and microphone in)
PCI slots	<p>Slot 1: 64 Bit, 5.0V, 33MHz</p> <p>Slot 2: Primary Graphics, 64 Bit, 3.3V, 66MHz</p> <p>Slot 3: 64 Bit, 5.0V, 33MHz</p> <p>Slot 4: Secondary Graphics, 64 Bit, 5.0V, 33MHz</p> <p>Slot 5: 32 Bit, 5.0V, 33MHz</p> <p>Slot 6: 32 Bit, 5.0V, 33MHz</p>
Keyboard	Universal Serial Bus (USB) keyboard

Table 1-1 HP VISUALIZE B Class and C Class Features

Computer Feature	Description
Mouse	Universal Serial Bus (USB) mouse

System Unit Front Panel and Removable Devices

Before powering on your system, you should become familiar with the system unit controls. Figure 1-1 shows the system unit front panel controls.

Figure 1-1 System Unit Front Panel Controls

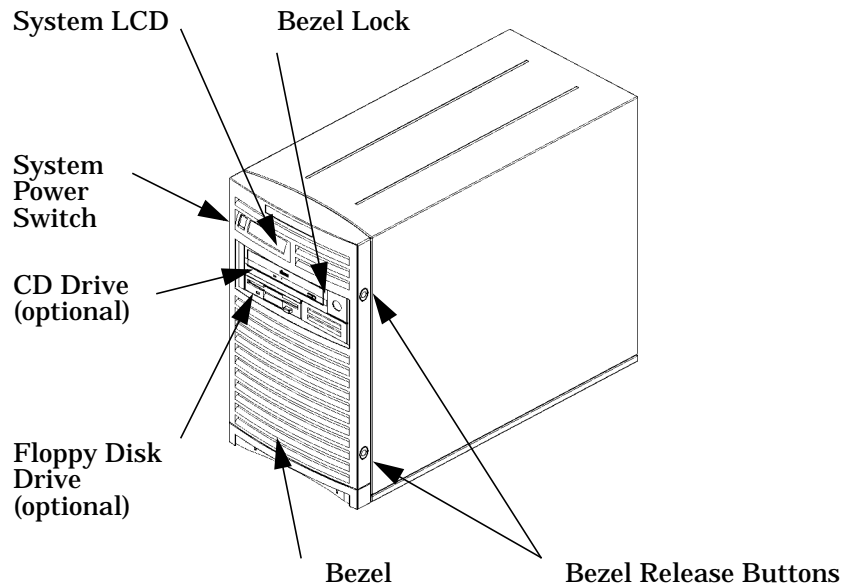





System LCD

The Liquid Crystal Display (LCD) is located on the left side of the front panel. There are two lines available in this LCD each line being 16 characters wide. The LCD displays messages about the state of the system, including chassis codes. The symbols in Figure 1-2 appear in the LCD if you have the HP-UX 10.20 or 11.0 operating system booted on your system. They represent the different system activities shown:

Figure 1-2

LCD Symbols HP VISUALIZE B Class and C Class Features

	Operating system running
	Disk access in progress
	Network receive in progress
	Network transmit in progress

For more information about the Liquid Crystal Display, read the section “LCD Information” in Chapter 7 of this document.

System Power Switch

The power switch is used to turn the system unit on and off. When you turn your computer off, the operating system executes an automatic `shutdown -q` command. This prevents any damage to programs and data on your system disk. Turning the power switch back on again automatically boots up the HP-UX 10.20 or 11.0 operating system if your system has been configured to auto boot. For information on setting auto boot, read the section “Setting the Auto Boot and Auto Search Flags” in Chapter 6 of this document.

Removable Media Devices

Depending on your configuration, you can have one or both of the following removable device drives in your system unit:

- CD drive
- Floppy disk drive

NOTE

You cannot have two devices of the same type. For example, you cannot have two CD drives, and you cannot have two floppy disk drives.

For a more detailed description of each of the removable media device's controls, see Chapter 2 for CD drive controls and Chapter 3 for floppy disk drive controls.

Figure 1-1 shows the system unit with a removable CD drive and a removable floppy disk drive.

System Unit Rear Panel Connectors

This section describes the following connectors on the system unit's rear panel:

- Audio connectors (including headphones and microphone)
- USB keyboard and mouse connectors
- HP parallel IEEE 1284 I/O connector
- 802.3 TP (Twisted Pair) LAN connector
- RS-232C serial I/O connectors
- SCSI connectors including Ultra2 Wide Low-Voltage Differential and Ultra Narrow Single-Ended SCSI
- TOC (transfer of control) button
- Power cord connector

NOTE

To maintain FCC/EMI compliance, verify that all cables are fully seated and properly fastened.

System Overview
System Unit Rear Panel Connectors

Figure 1-3 shows the locations of the connectors on the system unit's rear panel.

NOTE The Ultra Narrow Single-Ended SCSI and Ultra2 Wide Low-Voltage Differential SCSI connectors must have terminators connected to them when not in use.

Figure 1-3 System Unit Rear Panel Connectors

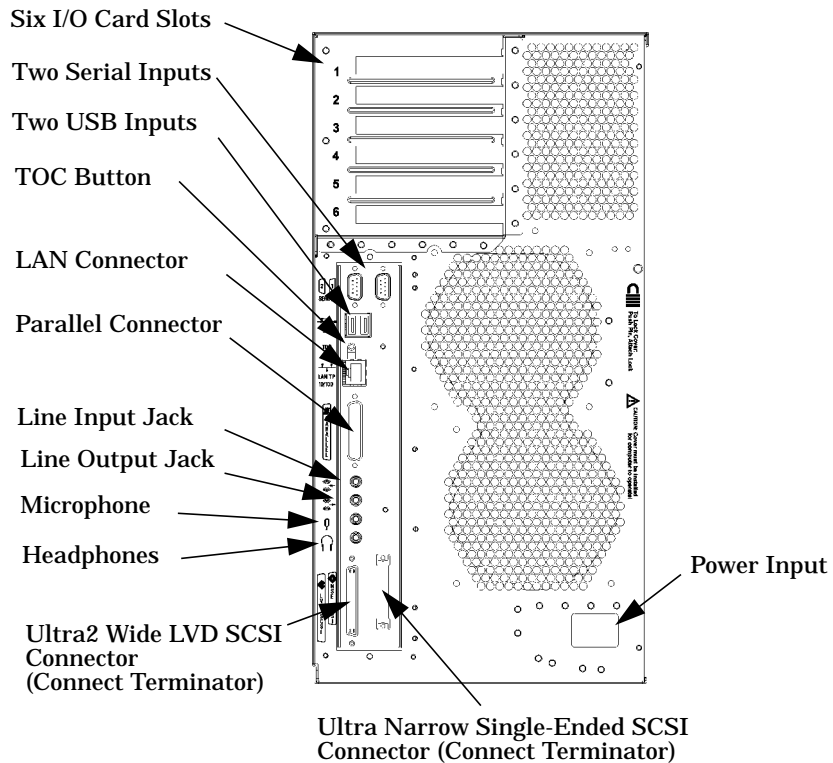

Audio Connectors

Your computer has audio input and output capability through external input and output connectors on the rear panel and through an internal speaker. The rear panel contains the Line IN, Line OUT, Mic IN, and Headphone OUT connectors. See Figure 1-4.

Figure 1-4

Audio Connectors

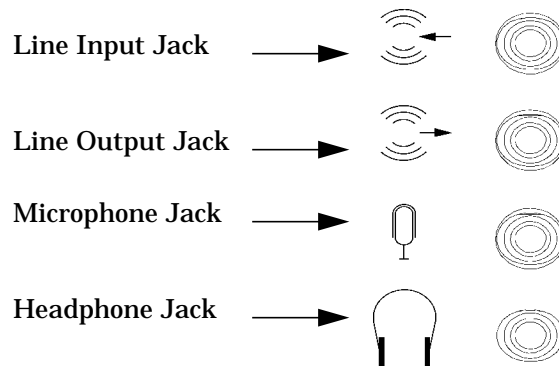

The audio connectors are standard stereo audio mini-jacks. Hewlett-Packard recommends using gold-plated plugs available through audio retailers for best quality recording and playback through the external connectors. A summary of the computer audio electrical specifications follows.

Table 1-2 Audio Electrical Specifications

Frequency Response	25Hz to 20kHz
Max Input Sensitivity/Impedance	
Line in	2.8V _{p-p} /10Kohm
Microphone	40mV _{p-p} /47Kohm
Max Output Level/Impedance	
Line out	2.8V _{p-p} /920ohm
Headphone	5.6V _{p-p} /110ohm
Speaker (internal)	n.a.

USB Connectors

There are two Universal Serial Bus (USB) connectors located on the rear panel of the computer. These USB connectors support only the HP keyboard, scroll mouse and hub. You can connect the HP keyboard, scroll mouse and hub in either of the USB connectors.

The mouse and keyboard were shipped with your system unit, and the HP hub can be ordered separately. Note that you should consult the documentation that accompanies each input device for specific information concerning its use.

For more information on the Universal Serial Bus, use your browser and the following URL:

<http://www.usb.org>

Keyboard

The USB connector provides an interface for the keyboard to the system. This keyboard provides the standard keycaps found on most PC keyboards.

HP Scroll Mouse

The HP scroll mouse (USB) has a left and right button that function the same as most mice. However, it also has a scroll wheel located between the two buttons that allows for vertical scrolling in a window. Note that vertical scrolling will only occur if you are in a window's vertical scroll bar. This scroll wheel also functions as a middle button when you press down on it. Essentially, the HP scroll mouse is a three-button mouse.

For general information on the various cursor shapes associated with different areas of HP CDE while using a mouse, see the *Using Your HP Workstation* document.

HP Hub for USB Devices

The HP USB hub provides you with the ability to connect more than one USB device to your computer, as well as with the ability to extend your USB device's cable length. As an example, you may desire to locate your computer's keyboard and mouse at a greater distance from your computer, but your keyboard and mouse cables are not long enough. To increase the cable length of your keyboard and mouse, you make use of the USB hub's extra cable length and connect the hub's cable to one of the two connectors on the back of your computer. You then connect the keyboard and mouse into their separate connectors on the USB hub.

HP Parallel I/O Connector

The 25-pin HP parallel I/O interface uses IEEE 1284 I/O interface protocols.

802.3 Network Connectors

Your computer has a built-in Twisted Pair (TP) connector for the 802.3 (ETHERNET) or 10 BaseT/100 BaseT network. Your computer will automatically select the correct network setting.

RS-232C Serial Input/Output Connector

You can attach a variety of pointing devices (such as a mouse or trackball), or peripheral devices (such as printers, plotters, modems, and scanners) to the RS-232C Serial Input/Output (SIO) ports on this computer. Consult the documentation that accompanies each pointing or peripheral device for specific information concerning its use.

The SIO ports are programmable. This means that you can set functions such as bit rate, character length, parity and stop bits using the System Administration Manager (SAM) or by selecting a system special device file with the functions already programmed. The SIO ports are used as an interface for serial asynchronous devices to the CPU.

Table 1-3 shows the SIO connector pin listings. The serial connectors are 9-pin D-sub connectors. Signal names are those specified in the EIA RS-232 standard.

Table 1-3 **Serial I/O Pins**

Pin No.	Signal	Description
1	DCD	Data Carrier Detect
2	RXD	Receive Data
3	TXD	Transmit Data
4	DTR	Data Terminal Ready
5	GND	Ground
6	DSR	Data Set Ready
7	RTS	Request To Send
8	CTS	Clear To Send
9	RI	Ring Indicator

SCSI Connectors

Use the SCSI connectors to connect external SCSI devices such as DDS-format tape drives. Consult the documentation that accompanies each SCSI device for specific information concerning its use. Refer to the chapter “SCSI Connections” for information about connecting SCSI devices to your computer.

NOTE

When attaching external Ultra Narrow Single-Ended SCSI (NSE SCSI) and Ultra2 Wide Low-Voltage Differential SCSI (LVD SCSI) devices, be sure to terminate the last device on the external SCSI bus with a terminator appropriate for that bus. Note that terminators for the LVD SCSI bus and the NSE SCSI bus are shipped with your product.

Power Cord Connector

Plug the workstation’s power cord into the power cord connector to provide AC power to the system.

Security Loop

On the back panel of your HP VISUALIZE B Class and C Class computer, you will find a device called a security loop. This device allows you to secure the internal parts of your computer by providing a means for locking the computer's left-side panel. Figure 1-5 provides a view of the security loop components.

Figure 1-5 Security Loop Components

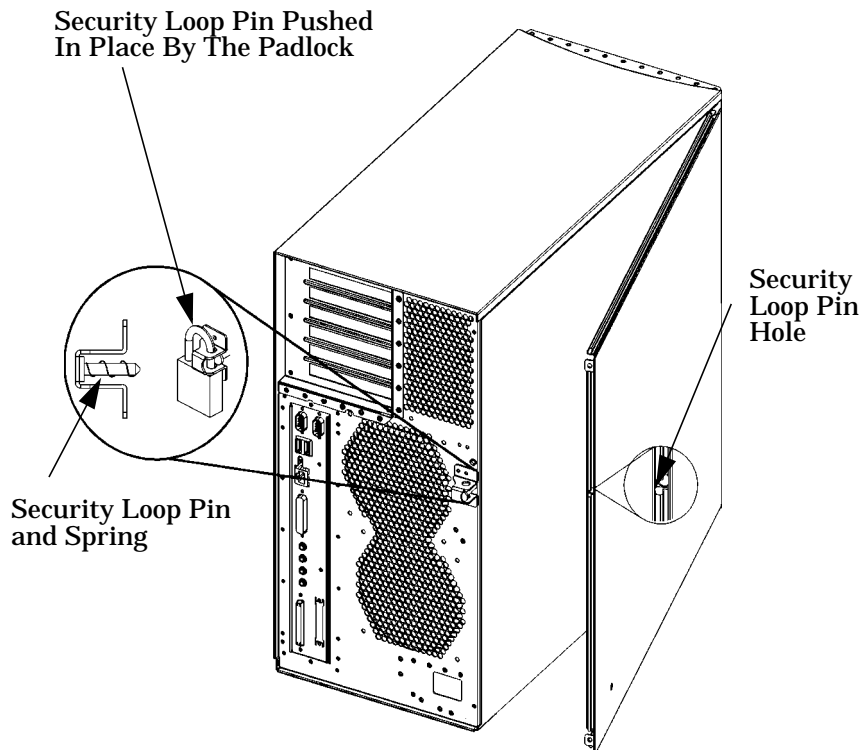

Locking Your System Unit's Left-Side Panel

To lock your system unit's left side panel, follow these steps:

1. Make sure the system unit's left side panel is closed. See Figure 1-6.

Figure 1-6 Closed Left-Side Panel

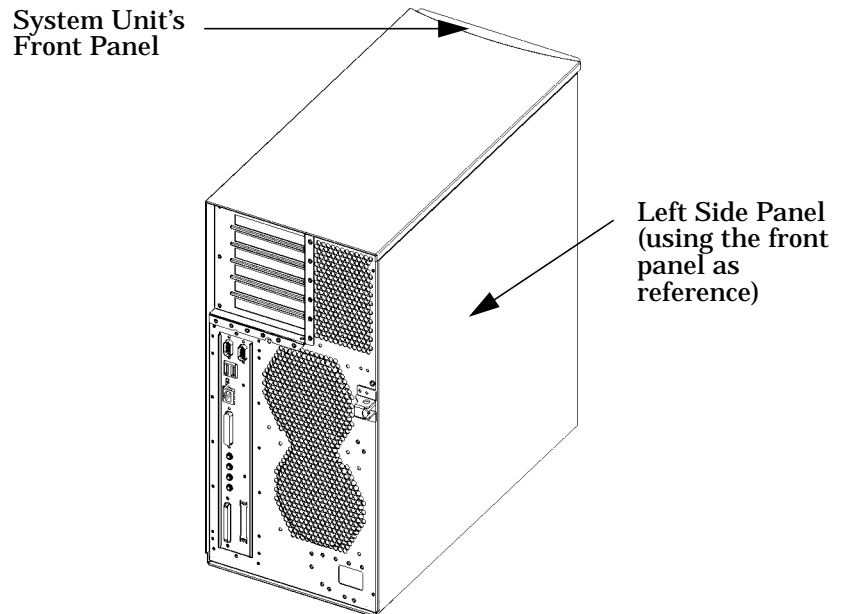

2. Push the security loop's pin into the security loop pin hole, and insert the padlock's latch through the holes at the top and bottom of the security loop. This locks the left side panel.
3. Lock the padlock. Your system unit's left side panel is now secure.

Memory

The main memory for an HP VISUALIZE B Class and C Class computer can vary from a minimum of 128 MBytes to a maximum of 2 GBytes. This computer has eight memory card slots. Note that you can install only 128 MByte and 256 MByte DIMM cards in these slots.

To install DIMM cards in your computer, follow the procedure in the section “Installing Additional Memory” in the chapter “Changing Your Computer Hardware Configuration.” Please keep in mind that if memory is installed improperly or it is bad your computer’s operating system will not boot-up, and a DIMM error will appear in your computers LCD. If a DIMM error does occur, please read the section “Memory Failures” in the chapter “Solving Problems.”

Monitors

You can use one of the following HP monitors with your computer:

- 19-inch, 1280×1024 color, 75Hz (A4575A)
- 19-inch, 1600×1200 color, 75Hz (A4575A)
- 21-inch, 1280×1024 color (stereo capability), 75Hz (A4576A)
- 21-inch, 1600×1200 color, 75Hz (A4576A)

Before using your monitor, you should become familiar with its controls, connectors and indicators. For information on these controls and indicators and on using your monitor, see the documentation that came with the monitor.

Note that connection to earlier HP monitors with 15-pin mini-DSub cables can be made using the A4168A adapter cable shipped with your system miscellaneous kit.

Operating System Overview

Your computer uses the HP-UX 10.20 or 11.0 operating system. Instant ignition systems (systems with preloaded software) have X-Windows, Hewlett-Packard's graphical user interface, and HP CDE installed and configured.

Please refer to the "Instant Ignition System Information" sheet that came with your system for details on configuration.

If your Instant Ignition system does not have the kernel preconfigured with all of the device drivers, you need to refer to the manual *Managing Systems and Workgroups* to configure your kernel.

If you have any questions about Instant Ignition, refer to *Using Your HP Workstation* for more information.

Note that both of the documents mentioned in the previous paragraphs can be found on the world-wide web at the following Uniform Resource Locator (URL):

`http://www.docs.hp.com/`

Information You Need to Record

Before you begin using your computer, take a moment to gather the following important information and record it in the appropriate subsection for future use:

- LAN Station ID
- Internet Protocol (IP) address
- Subnetwork mask

LAN Station ID

Locate the contents label that came with your computer shipping carton. Find the LAN Station ID listed there and record it here:

LAN Station ID: _____

The LAN Station ID can also be found on the back of the computer near the LAN connector. If the previous methods for locating your LAN Station ID do not work, you can get your LAN Station ID by executing the lanscan command in a terminal window.

IP Address and Subnetwork Mask Information

Get the IP address and the subnet mask information for your computer from either your system administrator or your network administrator and note them here:

IP Address: _____

Subnet Mask: _____

Powering Up Your System

After you have connected the various parts of the computer—for details, see the B Class and C Class Installation Sheet that came with your computer—you are ready to power up the system. At this point, there are two possibilities:

- Your computer has been “ignited;” that is, the HP’s Instant Ignition process has installed the operating system already. In this case, when you power up the computer, you will be presented with a series of questions asking you the machine’s host name, IP address, subnet mask, and other basic configuration questions (see the section “Getting Required Information”). When these are answered, the CDE login screen will appear.
- Your computer has not been “ignited;” that is, the HP’s Instant Ignition process has *not* installed the operating system already. In this case, you will need to install the operating system from the HP-UX CDs. For details, see the CD Booklet included with the CDs. When the operating system is installed, you will need to answer the questions noted above for the ignited system. After the questions have been answered, the CDE login screen will appear.

Once the CDE login screen appears, and you can log in as `root`—initially, there is no password. When you have logged in, you will be able to create other users’ accounts and do whatever other configuration and installations you require to get the machine into its desired state. See the *HP CDE Getting Started Guide* and the *User’s Guide* for instructions on typical tasks.

Getting Required Information

The start-up procedure for your workstation will require you to supply the following information. Therefore, you should find out this information before you turn the workstation on for the first time.

NOTE

If you are not the system administrator for your workstation, and you do not know the required information, ask your system administrator for the information.

Here is the information you will need. Please take time to fill in the blanks.

- *Host name* _____
The host name is sometimes called the “system name.”
- *Internet Protocol address* _____
You will need this address if you are connecting the workstation to a local area network.
- *Time zone* _____
This is the time zone where the workstation is located.
- *Optional networking parameters*
Ask your system administrator if you need to configure these parameters.

Subnetwork mask _____

Network gateway IP address _____

Local domain name _____

DNS server host name _____

DNS server IP address _____

Network Information Service domain name _____

System Overview
Powering Up Your System

- *Optional font server parameters*
You need to supply these parameters if you want the workstation to obtain its fonts on a network server. Ask your system administrator if you need to configure these parameters.

Font server name _____

Font server IP address _____

Turning on the Power

1. Turn on the monitor and any external peripherals (for example, printers) connected to the workstation.
2. Turn on the workstation. The workstation will run a series of self-tests.
3. After two or three minutes, a series of messages are displayed as various hardware and software subsystems are activated. Unless something is wrong with your system, you are not asked to respond to these messages.
4. A series of windows appears requesting the information you gathered in the previous section, such as your host name, IP address, and time zone. Enter the information as it is requested.

NOTE

You should enter the host name when requested; otherwise, you will get an error message when you log in.

If you do not have other pieces of information, press **Enter** to use the default value. You can provide missing information later by logging into a terminal emulator window as superuser and executing this command:

```
/sbin/set_parms
```

-
5. You are now asked if you want to set a `root` password. Specify the `root` password now. The `root` password is the password used for the superuser account. The superuser is a special user who has permission to perform all system administration tasks. The user name for the superuser is `root`.
 6. When you have finished answering all of the questions, the workstation completes its start-up sequence and displays the CDE login screen.

7. Log into your first CDE session as `root`. For information on logging into CDE, see the *Common Desktop Environment User's Guide*.

NOTE

You must log into the first session as `root`. This is because the system contains no other user accounts. Once you have created user accounts, you should log out as `superuser` and log back in as one of the other users.

8. Use the System Administration Manager (SAM) to set-up user accounts.

Documentation

The documentation for your system is located on the “Instant Information” CD. To view this CD, you need to read the special mounting instruction that come with it.

Here are the topics covered in this chapter:

- Operating the CD Drive
- Mounting and Unmounting a CD
- Verifying the CD Drive Operation
- Configuring the CD Driver
- Audio Control for the CD Drive
- CD Media Description

The instructions in this chapter assume you are using the HP-UX 10.20 or 11.0 operating system with the HP CDE interface.

For information about installing or removing a CD drive, see Chapter 5 of this document.

NOTE

Be sure you have read and understand the information on mounting and unmounting CDs before you begin using your CD drive.

NOTE

This chapter requires you to be superuser (`root`). If you cannot log in as `root`, contact your system administrator.

In this chapter, the terms “CD” and “CD drive” are use rather than “CD-ROM” and “CD-ROM drive” because the CD drives used in the B1000 and the C3000 can read the original CD-ROM disks, plus CD-R disks and the newer CD-RW disks (also called “CD-RAM” because they are rewritable). Thus, since not all CDs are ROMs any longer, that portion of the term has been dropped.

Incidentally, the CD drives also are multisession-capable.

CD Media Description

CDs, which can be CD-ROMs, CD-Rs, or CD-RWs, are 120mm (4.7 inches) in diameter, and use one data surface with a capacity of 600 megabytes. The data surface contains pits and flat spots arranged in a continuous spiral track, which is read at a constant speed. You may access files and data stored on a CD, but you may not write files or data to a CD.

CAUTION

Handle CDs by the edges only. Always be sure a CD is either in the CD drive or its protective case when not in use. This will reduce the chance of exposing the disk surface to dust. Over time, dust reduces the reliability of the read head in the CD drive.

Caring for CDs

Observe the following guidelines to help prevent data loss and prolong the life of you CD and CD drive:

- Use CDs in a clean environment to prevent dust particles from scratching disc surfaces.
- Store CDs in a cool, dry place to prevent moisture and heat damage.
- Do not try to clean the surface of a CD with cleaning solvents, as some cleaning solvents may damage the disk.

Operating the CD Drive

This section provides a description of the CD drive and it describes how to perform tasks with your CD drive.

CD Drive

The CD drive is a mass storage device that can read removable CD-ROM, CD-R, and CD-WR media. The drive supports the ISO 9660 and High Sierra format standards. You can access information from the drive like any other disk drive, except you cannot write to the drive. The drive contains a semiconductor laser for reading data optically, and includes an embedded controller with an ATAPI interface.

Controls and Features

Figure 2-1 and Table 2-1 describe the operating controls and features of the CD drive.

NOTE The exact positioning of CD Drive controls/features may vary depending on the model of the device.

Figure 2-1 CD Drive Controls and Features

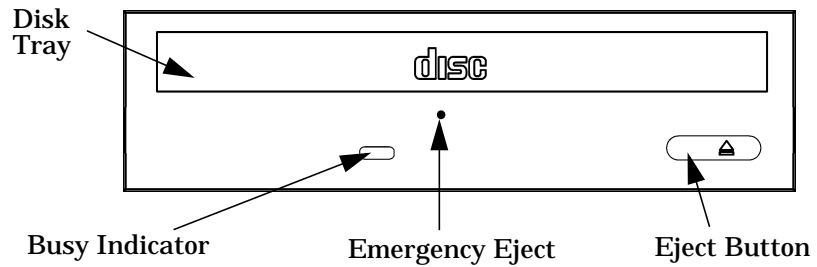

Table 2-1 CD Drive Operating Controls and Features

Control/Feature	Purpose
Busy Indicator	The Busy Indicator blinks during a data transfer.
Eject Button	The Eject Button when pressed opens the Disk Tray for removal or insertion of a disk. When the drive is in use, you must press the eject button for more than one second to open the Disk Tray.
Emergency Eject	You can open the Disk Tray when the computer does not have power by inserting the end of a paper clip into this opening.
Disk Tray	The Disk Tray holds the CD. This style of CD drive does not use a disk caddy.

Note that there is neither a volume control nor a headphone jack on the front of the CD drive. To listen to an audio CD, use the headphone jack on the rear panel, and control the sound volume via software called “xmcd” (for details, see “Audio Control for the CD Drive” on page 63).

Loading and Unloading a CD

This section explains how to load or unload a CD.

NOTE

To use the file system on a CD, you must be superuser (`root`) and mount the disk as discussed in the section “Mounting a CD Using SAM.” Once the CD has been mounted, you must unmount it before removing the CD. Unmounting a CD is discussed in the section “Unmounting a CD Using SAM.”

Loading a CD

This CD drive has an automatic loading/ejecting feature. To load a CD in the CD drive, follow these steps:

1. Press and release the eject button on the CD drive. The disk tray opens as shown in Figure 2-2.

Figure 2-2 Open CD Tray

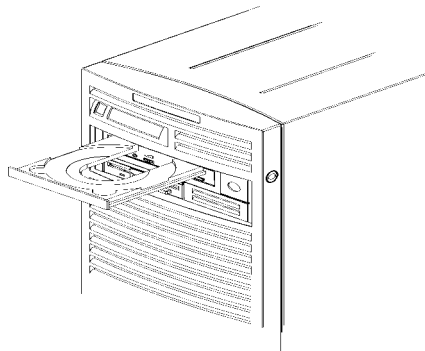

2. Hold the disk by the edges with the label side up and place it in the disk tray as shown in Figure 2-3.

Figure 2-3 **Placing the CD in the Disk Tray**

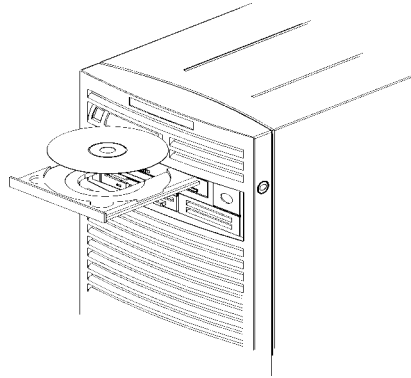

3. Press the eject button to close the tray as shown in Figure 2-4.

Figure 2-4 **Closed Disk Tray**

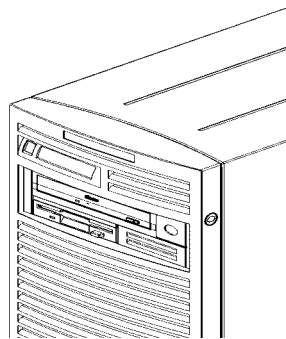

Unloading a CD

To unload a disk from the Disk Tray, follow these steps:

1. Press and release the eject button on the CD drive to open the disk tray.
2. Grasp the disk by the edges and lift it out of the disk tray.
3. Press the Eject Button to close the disk tray.

Locating Help

If you have trouble with any of the procedures for using your CD drive, see the chapter “Solving Problems” in this document.

Mounting and Unmounting a CD

This section of the chapter explains how to mount and unmount a CD using the System Administration Manager (SAM).

The procedures in this section require you to log in as `root`. If you cannot log in as `root`, contact your system administrator.

Mounting a CD Using SAM

To access your CD drive, you must mount a CD every time you insert it into the drive. This applies to CDs with file system information only. If you wish to load a music CD, for example, you would not need to mount the disk. Mounting a disk with file system information gives the disk a path name that allows your computer to communicate with it. You must unmount the CD before removing it from the drive.

To mount a CD on an HP-UX 10.20 or 11.0 operating system, perform the steps covered in this section.

1. Log in as `root`.
2. Move the mouse pointer to the **Application Manager** control for tools and click the left mouse button. Alternatively you can execute `sam` at a terminal window command prompt and skip to step 5.



Using Your CD Drive

Mounting and Unmounting a CD

3. Double click on the **System_Admin** icon in the **Application Manager** window.

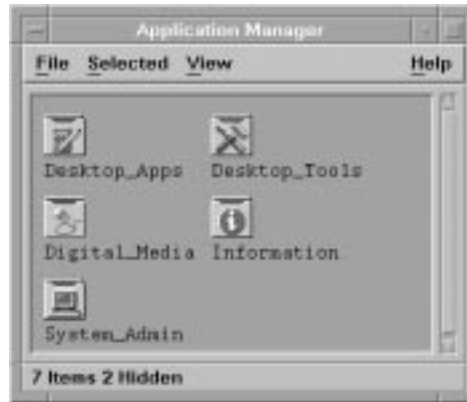

4. Double click on the Sam icon in the **Application Manager -- System_Admin** window. If you are **root**, the **System Application Manager (SAM)** will appear on your screen.



5. Double click on the **Disk and File System** icon.



6. Double click on the **Disk Devices** icon.



The following screen message is displayed:

Scanning the system's hardware...

The **Disk and File Systems** window opens containing a list of devices installed in this system. From the list of devices, choose the CD drive you would like to configure as a file system by clicking on the device to highlight it.

7. Click on **Add** in the **Actions** menu. For this example you will select the item **Not Using the Logical Volume Manager**. However, you can select any appropriate item from the **Actions** menu.
8. Enter the mount directory name (for example, `/disk1`) in the **Mount Directory** field of the **Add Disk without LVM** window.
9. Click on the **Modify Defaults...** button. In the **Modify Defaults** window, select the **Read Only** item from the Access button menu. Next, unselect the **Create New File System** item by clicking on it. Exit the **Modify Defaults** window by clicking on the **OK** button.
10. Click on the **OK** button in the **Add Disk without LVM** window. You will need to wait for a short time for the CD to be mounted. When the **Add Disk without LVM** window disappears and **CDFS** appears in the Use column of the **Disk and File Systems** window, you have mounted the CD.

Unmounting a CD Using SAM

You must unmount a CD before it will eject from the drive.

NOTE

Before you unmount a CD, make sure that your working directory is set to a directory other than the one under which the disk was mounted.

To unmount a CD on an HP-UX 10.20 or 11.0 operating system, perform the steps covered in this section.

1. Log in as `root`.
2. Move the mouse pointer to the **Application Manager** control for tools and click the left mouse button. Alternatively you can execute `sam` at a terminal window command prompt and skip to step 5.



3. Double click on the **System_Admin** icon in the **Application Manager** window.

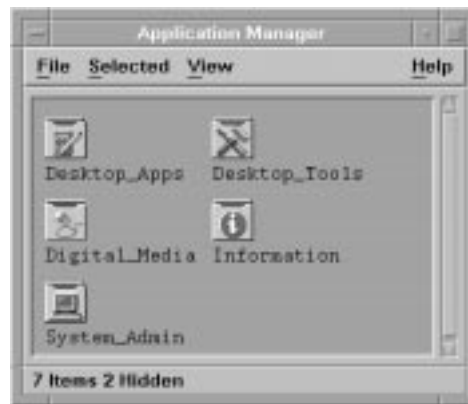

4. Double click on the **Sam** icon in the **Application Manager -- System_Admin** window. If you are **root**, the **System Application Manager (SAM)** will appear on your screen.



5. Double click on the **Disk and File System** icon.



6. Double click on the **Disk Devices** icon.



The following screen message is displayed:

```
Scanning the system's hardware...
```

The **Disk and File Systems** window opens containing a list of devices installed in this system. From the list of devices, choose the CD drive you would like to remove (unmount) by highlighting that device.

Mounting and Unmounting a CD

7. Click on **Remove** in the **Actions** menu. In the window that next appears, click on the **Yes** button. This will unmount the CD. You will need to wait for a short time before the CD is unmounted. The CD is successfully unmounted when you see `Unused` in the `Use` column of the **Add Disk without LVM** window.

Verifying the CD Drive Operation

To verify that your workstation can communicate with the CD drive, follow the steps covered in this section. Note that to perform the steps required in this section, you must be superuser (`root`). If you cannot log in as `root` contact your system administrator.

1. Log in as `root`.
2. Type the following command at the shell prompt and press **Enter**:

```
/usr/sbin/iocan -d sdisk
```

After a few seconds the `iocan` utility lists all of the I/O devices that use the “`sdisk`” driver. Your CD drive should be among the devices listed. The list appears similar to the following:

H/W Path	Class	Description
10/0/15/1.5.0	disk	SEAGATE ST39102LC
10/0/15/1.6.0	disk	SEAGATE ST39102LC
10/0/14/0.0.0	disk	TEAC CD-532E-B

If `iocan` does not detect any usable I/O system devices, such as the CD drive, nothing is output and you are returned to the system prompt. Since this indicates possibly that the driver for the CD drive is not configured, read the section “Configuring the CD Driver” in this chapter.

Configuring the CD Driver

If you reload software or rebuild the Instant Ignition system on your computer, you may need to reconfigure the HP-UX kernel to add the CD driver. Use the **SAM** utility to add the CD driver and build a new HP-UX kernel.

For more information about how to reconfigure the kernel using **SAM**, see the following manuals:

- *Managing Systems and Workgroups*
- *Using HP-UX*

Audio Control for the CD Drive

In order to control the playing of audio CDs on your CD drive, you will need a third party “CD player” application. One such application that supports HP workstations is `xmcd`. This is a third-party “CD player” utility that runs on an X window system using the Motif graphical user interface. The `xmcd` utility is not supported by Hewlett-Packard. Since the `xmcd` utility is not a part of HP-UX, you will need to download it off the web using your web browser and this URL:

`http://metalab.unc.edu/tkan/xmcd`

Installing the `xmcd` Utility

Here is the procedure for downloading the `xmcd` utility to your system:

1. Log in as `root`.
2. Type the previously given URL into the entry box on your web browser and press **Enter**.
3. Select the menu item labeled **Downloads** found on the `xmcd` homepage.
4. Scroll down to the section “Select your platform:” on the **Downloads** web page and select the item labeled “HP-UX 9.x and later (HP PA-RISC).”
5. Wait for a few seconds for the **Save As...** pop-up window to appear. In this window, click in the **Selection** entry box and type the following path and file name:

`/tmp/xmcdbin.tar.gz`

Next, click the **OK** button. This completes the download of `xmcd` to your system.

6. Follow the instructions in the section “Instructions to unpack `xmcd` binary” found on this **Binary Downloads** web page. This will complete the installation of the `xmcd` utility.

Using the xmcD Utility

The instructions in the section assume that you are using the HP-UX 10.20 or 11.0 operating system with the HP CDE interface. The `xmcD` utility must also be installed on your system. See the section “Installing the `xmcD` Utility.”

To load and play an audio CD, follow the steps in this procedure.

1. Load the audio CD. See the section “Loading a CD” in this chapter.
2. Insert the headphone plug into the headphone jack located on the back of your system unit.

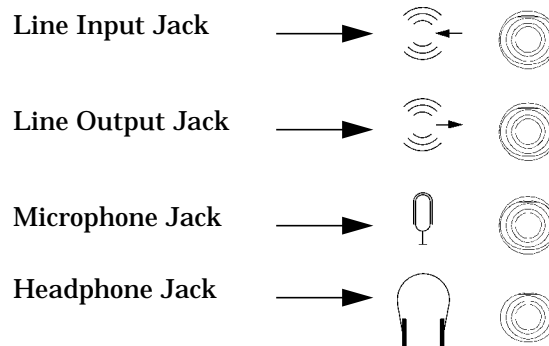

3. Click on the **Audio** icon located on your HP CDE control panel.

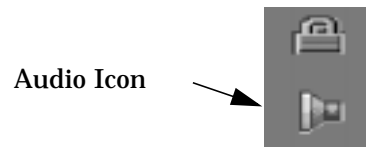

4. Click on the **Monitoring** checkbox in the **Audio** window to select it. Then select the **Output** menu and click on the **Headphones** item in the menu list. In the **File** menu select the item **Close**, this will close the **Audio** window and save your settings. Note that the **Output Volume** slider in the **Audio** window does not control the CD drive's volume level. To control the CD drive's volume, you need to use the volume slider on the `xmcd` user interface. See the window in step 5.

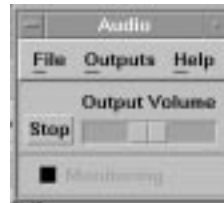

5. Start the utility by typing `xmcd` at the prompt and pressing **Enter**.

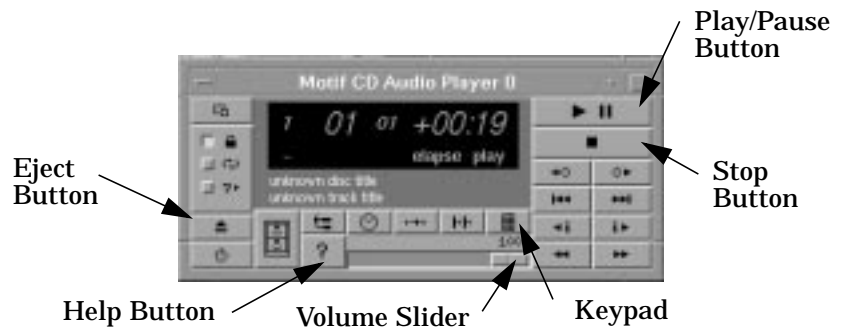

Now that you have your audio CD player started, put on your headphones and press the **Play** button to listen to the audio CD. Note that pressing the **Help** button will give you information on how to use the rest of the CD player's buttons.

Using Your CD Drive
Audio Control for the CD Drive

3 **Using Your 3.5-Inch Floppy Disk Drive**

This chapter describes how to perform tasks that allow you to archive to or transfer data from the 3.5-inch floppy disk drive.

The instructions in this chapter assume you are using the HP-UX 10.20 or 11.0 operating system with the HP CDE interface.

NOTE

When examples of user input are given in this chapter, enter them at the command-line prompt in an HP CDE terminal window.

Some procedures in this chapter require you to log in as superuser (`root`). If you cannot log in as `root`, contact your system administrator.

Here are the topics covered in this chapter:

- Operating the Floppy Drive
- Verifying the Floppy Drive Configuration
- Additional Floppy Drive Information.

For information on installing and removing a floppy disk drive, see Chapter 5 of this document.

Operating the Floppy Drive

This section describes how to perform tasks with your 3.5-inch floppy disk drive.

Floppy Disk Drive

The floppy disk drive is a random access read/write mass storage device that uses removable floppy diskettes. The drive supports the 1.44 Mbyte High Density standard. You can access information from the drive like any other disk drive, that is you can write information to it and read information from it.

Controls and Features

Figure 3-1 and Table 3-1 describe the operating controls and features of the floppy disk drive.

Figure 3-1

Floppy Disk Drive Controls and Features

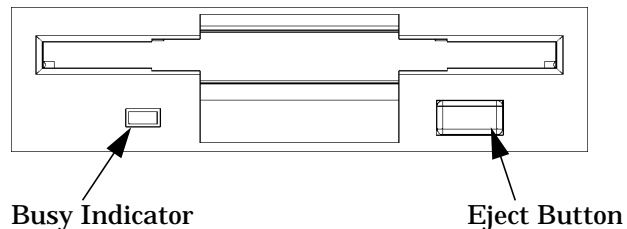

Table 3-1

Floppy Disk Drive Operating Controls and Features

Control/Feature	Purpose
Busy Indicator	The Busy Indicator illuminates during a data access operation and blinks during a data transfer.
Eject Button	The Eject Button, when pressed, ejects the floppy diskette from the floppy disk drive.

Using the Floppy Diskette

This section describes basic information needed to use your floppy diskettes.

Setting the Write-Protect Tab on a Diskette

You can only store or change information on a diskette when the write-protect tab is in the write position. So, before trying to write to the diskette, make sure that the write-protect tab is in the write position, as shown in Figure 3-2.

Figure 3-2 **Setting the Write-Protect Tab on a Floppy Diskette**

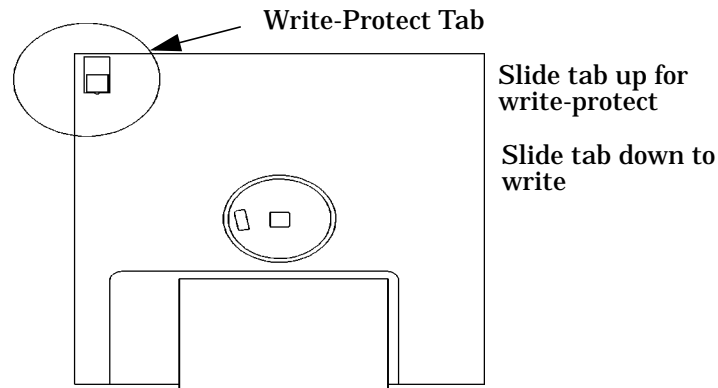

To protect files on a diskette from being overwritten, set the write-protect tab to the write-protect position.

NOTE

The write-protect tab should always be in the write position for formatting a new diskette and transferring data to a diskette.

Inserting and Removing a Diskette

Follow these steps to insert and remove a diskette from the floppy disk drive.

1. Insert the diskette into the drive, as shown in Figure 3-3.

Figure 3-3 **Inserting and Removing a Floppy Diskette**

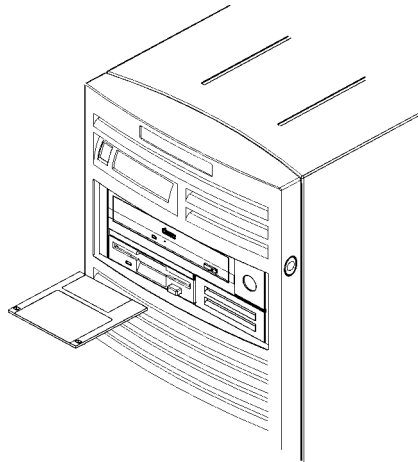

2. Push the diskette into the floppy drive until it clicks into place.
3. Remove the diskette by pressing the eject button (see Figure 3-1) and taking it out of the drive.

Using Device Files

Device files are special files that tell your system which pathway through the system hardware to use when communicating with a specific device. Device files also describe the type of device. You will need to know the special device file associated with your floppy disk drive so that you can write data to it or read data from it.

NOTE

The device file names depend on the naming conventions of your particular system.

Using Your 3.5-Inch Floppy Disk Drive

Operating the Floppy Drive

To determine what device files are available for use with your floppy drive, use the following procedure:

1. Log in as `root`.
2. Move the mouse pointer to the **Application Manager** control for tools and click the left mouse button. Alternatively you can execute `sam` at a terminal window command prompt and skip to step 5.



3. Double click on the **System_Admin** icon in the **Application Manager** window.

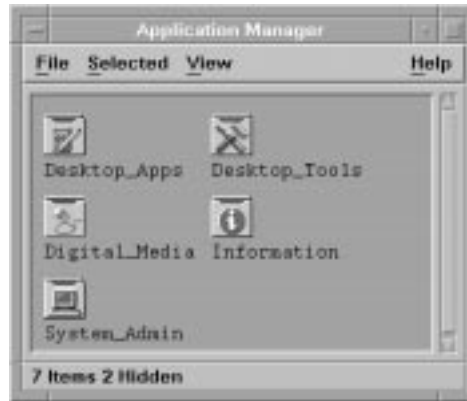

4. Double click on the **Sam** icon in the **Application Manager -- System_Admin** window. If you are **root**, the **System Application Manager (SAM)** will appear on your screen.



5. Double click on the **Disk and File System** icon.



6. Double click on the **Disk Devices** icon.



The following screen message is displayed:

```
Scanning the system's hardware...
```

The **Disk and File Systems** window opens containing a list of devices installed in this system. From the list of devices, choose the floppy disk drive you would like to configure as a file system by clicking on the device to highlight it.

7. Select the **Actions** menu and then select the menu item **View More Information**. A window opens with a list of information for the floppy drive, including the device files.

Formatting a New Diskette

If you have floppy diskettes that have been previously formatted using the `mediainit` utility, you can skip this section. Otherwise, you must always format a new floppy diskette with the `mediainit` utility before using the diskette. To format a new floppy diskette, follow these steps:

1. Log in as `root`.
2. Make sure that the write-protect tab on the floppy diskette is in the write position, as shown in Figure 3-2.
3. Insert the diskette into the floppy disk drive.
4. Type the following at the prompt and press **Enter**:

```
mediainit -f 16 devicefile
```

where `16` is the High Density (HD) format option and *devicefile* is the device file as listed by SAM. See the section “Using Device Files” in this chapter. For a listing of format options, see the `floppy` manual page. To view this manual page, type the following at the prompt and press **Enter**:

```
man floppy
```

Transferring Data To and From a Floppy Diskette

This section describes how to transfer data (reading and writing) to and from your floppy diskette using the HP-UX `tar` command with your floppy drive's device file.

You need to set the write-protect tab to the *write* position to transfer data to the diskette. The write-protect tab can be in either position when restoring data from a diskette or listing the files on a diskette.

Saving Files to a Floppy Diskette

Use the following instructions to save files to a floppy diskette:

1. Check the write-protect tab on the floppy diskette to ensure that it is in the *write* position.
2. Load the formatted floppy diskette into the disk drive.
3. Type the following command in a terminal window at the prompt and press **Enter**:

```
tar -cvf devicefile pathname
```

where *devicefile* is the device file as listed by SAM (see the section “Using Device Files” in this chapter), and *pathname* is the path name of the file or directory containing files that you want to write to the diskette.

Restoring Files from a Floppy Diskette to Your System

Use the following instructions to restore files from a floppy diskette to your system:

1. Load the floppy diskette into the disk drive.
2. Type the following command in a terminal window at the prompt and press **Enter**:

```
cd directory_path
```

This command changes you to the directory in which you want the files to reside.

3. Enter the following command at the prompt and press **Enter**:

```
tar -xvf devicefile pathname
```

where *devicefile* is the device file as listed in **SAM** (see the section “Using Device Files” in this chapter) and *pathname* is the path name of the file or directory containing files that you want to restore from the diskette. If you do not specify *pathname*, everything on the floppy diskette is restored.

Listing the Files on a Floppy Diskette

Use the following instructions to list the files on a floppy diskette:

1. Load the floppy diskette into the disk drive.
2. Enter the following command in a terminal window at the prompt and press **Enter**:

```
tar -tvf devicefile
```

where *devicefile* is the device file as listed by **SAM**. See the section “Using Device Files” in this chapter. Note that this command will list all files on the floppy diskette.

Troubleshooting

If you have trouble with any of the procedures for using your floppy disk drive, see Chapter 7 of this document, “Solving Problems.”

Verifying the Floppy Drive Configuration

To verify that your workstation can communicate with the floppy drive, use the `ioscan` command in a terminal window to see which devices are currently in use on your system. Note that you will have to be superuser or root to use the `ioscan` command.

Enter the following command at the prompt and press **Enter**:

```
/usr/sbin/ioscan -fnC floppy
```

After a few seconds, the `ioscan` utility lists all of the I/O devices that use the “floppy” class. Your floppy drive should be among the devices listed. The list appears similar to the following:

```
Class  I  H/W Path      Driver  S/W State  H/W Type  Description
=====
floppy 0  10/0/14/1/4.1  sioflop CLAIMED   DEVICE    HP_PC_FDC_FLOPPY
                               /dev/floppy/c0t1d0  /dev/rfloppy/c0t1d0
```

If `ioscan` does not detect any usable I/O system devices that use the “floppy” class, such as the floppy disk drive, nothing is output and you are returned to the system prompt. If this is the case, refer to Chapter 7, “Solving Problems.”

If the floppy disk driver is not configured, `ioscan` returns the following message:

```
ioscan: Device driver floppy is not in the kernel
```

If you receive this message, go to the section, “Configuring the Floppy Driver” in this chapter for information on adding the `sioflop` driver to the HP-UX kernel configuration.

Additional Floppy Drive Information

This section provides information about configuration of the floppy disk driver and information about useful HP-UX commands for copying and listing floppy disk files.

Configuring the Floppy Driver

If you reload software or rebuild the Instant Ignition system on your computer, you may need to reconfigure the HP-UX kernel to add the floppy disk driver. Use the **SAM** utility to add the `sioflop` disk driver and build a new HP-UX kernel.

For more information about how to reconfigure the kernel using **SAM**, see the following manuals:

- *Managing Systems and Workgroups*
- *Using HP-UX*

For More Information

For more information on using `tar` and a complete list of the command arguments, refer to the `tar` man page by typing the following command in a terminal window at the prompt and pressing **Enter**:

```
man tar
```

You can mount the floppy drive as a file system using the SAM utility. Be sure to unmount the drive before removing it as a file system. For more information about how to mount and unmount the floppy drive, see the manual *Using HP-UX*.

For more information on copying data to or from your system to other media, including your floppy diskette, refer to the `cpio` man page by typing the following command in a terminal window at the prompt and pressing **Enter**:

```
man cpio
```

For more information on copying to or from DOS files, refer to the `doscpc` man page by typing the following command in a terminal window at the prompt and pressing **Enter**:

```
man doscpc
```

For more information on listing DOS directories, refer to the `dosls` man page by typing the following command in a terminal window at the prompt and pressing **Enter**:

```
man dosls
```

For more information on using your floppy disk drive and floppy diskettes, refer to the `floppy` man page by typing the following command in a terminal window at the prompt and pressing **Enter**:

```
man floppy
```

For more information on using the `mediainit` command, refer to the `mediainit` man page by typing the following command in a terminal window at the prompt and pressing **Enter**:

```
man mediainit
```

Using Your 3.5-Inch Floppy Disk Drive
Additional Floppy Drive Information

4 **SCSI Connections**

This chapter provides information about connecting Small Computer System Interface (SCSI) devices to an HP VISUALIZE B Class and C Class computer.

SCSI Connections

Here are the topics covered in this section:

- SCSI bus differences
- SCSI Restrictions
- Determining SCSI Bus Length
- Assigning SCSI Device IDs
- Connecting to the SCSI Ports

The instructions in this chapter assume you are using the HP-UX 10.20 or 11.0 operating system with HP CDE.

NOTE

When attaching external SCSI devices, be sure to terminate the last device on the external SCSI bus. Note that these terminators were shipped with your system.

SCSI Bus Differences

A Small Computer Systems Interface (SCSI) bus is an IEEE standard bus for connecting your workstation to internal and external devices (SCSI devices) running at different speeds. There may be one device connected to the external SCSI port or several SCSI devices may be daisy chained together and connected to the external SCSI port. Examples of these SCSI devices are 4-mm DDS-format tape drives and hard disk drives.

There are two types of SCSI buses available with this workstation—an Ultra Narrow Single-Ended SCSI bus (NSE SCSI), and an Ultra2 Wide Low-Voltage Differential SCSI bus (LVD SCSI). The following table shows the specification differences between these SCSI buses.

CAUTION

Currently Hewlett-Packard does not support mixing Ultra Narrow Single-Ended and Ultra2 Wide Low-Voltage Differential devices on any one bus type.

Table 4-1 SCSI Bus Differences

Type	Data Transfer Rate	Data Bus Width	Available SCSI Addresses ¹	Maximum Cable Length	Device Physical Location ²
Ultra Narrow Single-Ended	Up to 20 Mbytes/sec	8 bits	0 through 6	3.0 meters (9.84 feet)	External
Ultra2 Wide Low-Voltage Differential	Up to 80 Mbytes/sec	16 bits	0 through 6; 8 through 15	12 meters (39.37 feet)	Internal and external

1. Address 7 is reserved for host controller use on all buses.
2. This information is specific to the HP VISUALIZE B Class and C Class computer.

SCSI Restrictions

This section describes the SCSI restrictions that apply to your workstation in the following areas:

- Cables
- Terminators
- Number of Devices Per SCSI Bus
- Considerations for Selecting SCSI Devices

Note that the narrow single-ended SCSI bus supports only 7 devices because address 7 is reserved by the system. The Ultra2 Wide Low-Voltage Differential SCSI bus supports only 15 devices because address 7 is reserved by the system.

Cables

Only SCSI cables approved by HP can be used to connect your workstation to any SCSI devices. HP offers the following SCSI cables for Ultra Narrow Single-Ended SCSI devices:

Table 4-2

Ultra Narrow Single-Ended SCSI Cables

Cable Number	Cable Length	Description
C2955A	0.5m	50-pin HDTS ¹ to 50-pin HDTS
C2908A	1.0m	
C2956A	1.5m	
C2957A	2.0m	

1. High Density Thumb Screw (HDTS)

HP offers the following SCSI cables for connecting externally connected devices to the system Ultra2 Wide Low-Voltage Differential port:

Table 4-3 Ultra2 Wide Low-Voltage Differential SCSI Cables

Cable Number	Cable Length	Description
C2978A	0.5m	68-pin HDTS ¹ to 68-pin HDTS
C2979A	1.5m	
C2911B	1.0m	
C2924B	2.5m	
C2361A	1.0m	68-pin VHDCI ² to 68-pin HDTS
C2362A	2.5m	
C2363A	10.0m	
C2365A	5.0m	

1. High Density Thumbscrew (HDTS)
2. Very High Density Cabled Interconnect (VHDCI)

CAUTION

SCSI cables approved by HP are designed to function within the SCSI tolerances for HP devices. Use of other cables can result in significant problems with system operation.

Always use the shortest possible cable(s) for your configuration.

NOTE

See “SCSI Bus Length Constraints” later in this chapter to determine the total length of your cables.

Terminators

The terminators for Ultra2 Wide Low-Voltage Differential SCSI (LVD SCSI) and Ultra Narrow Single-Ended SCSI (NSE SCSI) are different. The NSE SCSI terminator has 50 pins and will fit on a NSE SCSI connector. The LVD SCSI terminator has 68 pins and will fit on a LVD SCSI connector. Note that these SCSI terminators were shipped with your system.

CAUTION

It is necessary to put a terminator on unused SCSI connectors on the back panel of the system. However, if SCSI devices are attached to the bus via these connectors, the external device connected to the SCSI bus must be terminated with a SCSI terminator. If you do not already have the SCSI terminators, you must order terminator A1658-63012 (for the 50-pin terminator; NSE SCSI) or A4986-63008 (for the 68-pin terminator; LVD SCSI) from Hewlett-Packard.

Number of Devices Per SCSI Bus

The number of SCSI devices per bus is limited (see Table 4-1). Before adding another SCSI device, determine if the system can support the additional device.

This workstation offers the following types of SCSI buses, each with their own configuration constraints:

- Ultra Narrow Single-Ended SCSI bus
- Ultra2 Wide Low-Voltage Differential SCSI bus

Considerations for Selecting SCSI Devices

SCSI devices supported by the Hewlett-Packard Company for the Ultra Narrow Single-Ended (NSE) and Ultra2 Wide Low-Voltage Differential (LVD) SCSI buses have been qualified as SCSI devices which meet NSE and LVD specifications. Contact your local HP sales representative for a current list of SCSI devices supported by HP for use on the Ultra Narrow Single-Ended and Ultra2 Wide Low-Voltage Differential SCSI buses.

If devices other than those supported by HP are connected to the Ultra Narrow Single-Ended or the Ultra2 Wide Low-Voltage Differential SCSI

bus on this system, they must adhere to cabling, termination and bus length restrictions discussed in this chapter to assure functionality of the SCSI busses.

Because Ultra2 Wide Low-Voltage Differential SCSI is a relatively new technology, there can be products which are advertised as LVD compliant, but may not meet LVD specifications. Therefore, additional caution must be exercised when choosing Ultra2 Wide Low-Voltage Differential SCSI devices other than those supported by Hewlett-Packard Company to connect to the Ultra2 Wide Low-Voltage Differential SCSI bus on this system. For example, the cabling inside one of these devices in question may not have a differential impedance between 110 and 135 ohms and it may be constructed in a way such that the device has considerable crosstalk on critical signals, such as Reset, Select and Busy. Failure to strictly adhere to the Ultra2 Wide Low-Voltage Differential SCSI bus specifications will impact the performance of the LVD bus. The Ultra2 Wide Low-Voltage Differential interface is a much higher performance SCSI bus than previous SCSI buses and is more sensitive to adherence to the electrical specifications.

Low-voltage differential signaling specifications are described in the *SCSI Parallel Interface-2 (SPI-2)* document and in the *Electrical Characteristics of Low Voltage Differential Signaling (LVDS) Interface Circuits TIA/EIA-644* document. Both of these documents can be obtained from:

Global Engineering Documents
15 Inverness Way East
Englewood, CO 80112-5704
800-854-7179 or 303-397-7956

SCSI Bus Length Constraints

This section discusses SCSI bus length constraints for the Ultra Narrow Single-Ended SCSI bus and the Ultra2 Wide Low-Voltage Differential SCSI bus.

Ultra Narrow Single-Ended SCSI Bus Length

The maximum cable length for an Ultra Narrow Single-Ended SCSI bus is 3 meters. The HP VISUALIZE B Class and C Class system uses a small portion of this maximum cable length.

NOTE

When calculating the total Ultra Narrow Single-Ended SCSI cable/bus/trace length used externally, remember to account for cables connecting external devices together as well as the bus length internal to those devices.

There are two total cable length specifications that apply to the Ultra Narrow Single-Ended SCSI bus on your computer. Note that these specifications are based on the requirement that the SCSI device being connected to the NSE SCSI bus does not exceed the maximum capacitance of 25 picofarads (pF). Please check with the vendor of your SCSI device if you are not sure of your devices maximum capacitance.

Here are the total cable length specifications:

- For a total of one to four devices being connected to the NSE SCSI bus the total length of cable used should not exceed 3.0 meters.
- For a total of five to eight devices being connected to the NSE SCSI bus the total length of cable used should not exceed 1.5 meters.

Please remember that the computer is counted as one of the total devices, and the internal length of its cabling is 0.15 meters. This length needs to be considered in your total cable length determination.

Ultra2 Wide Low-Voltage Differential SCSI Bus Length

The maximum cable length for an Ultra2 Wide Low-Voltage Differential SCSI bus is 12 meters. The HP VISUALIZE B Class and C Class system uses 1 meter of this maximum cable length internally. This means that up to 11 meters of cable can be used for connecting external Ultra2 Wide Low-Voltage Differential SCSI devices to this workstation.

NOTE

When calculating the total Ultra2 Wide Low-Voltage Differential SCSI cable/bus/trace length used externally, remember to account for cables connecting external devices together as well as the bus length internal to those devices.

Assigning SCSI Device IDs

Before assigning a SCSI device ID to a new SCSI device, you need to determine which SCSI device IDs are available. To view the SCSI IDs already in use, type the following command at the prompt and press Enter:

```
/usr/sbin/ioscan -f
```

After a few moments, the `ioscan` utility lists all of the I/O devices it could find. The list appears similar to the following:

Class	I	H/W Path	Driver	S/W State	H/W Type	Description
bc	0		root	CLAIMED	BUS_NEXUS	
bc	1	10	ccio2	CLAIMED	BUS_NEXUS	I/O Adapter
ba	0	10/0	ROPEtoPCI	CLAIMED	BUS_NEXUS	PCI Bus Bridge - ROPEtoPCI
graphics	0	10/0/1/0	graph3	CLAIMED	INTERFACE	PCI(103c1005)
lan	0	10/0/12/0	btlan3	CLAIMED	INTERFACE	PCI(10110019)
audio	0	10/0/13/0	audio	CLAIMED	INTERFACE	PCI(11d41189)
ext_bus	0	10/0/14/0	side	CLAIMED	INTERFACE	PCI(100b0002)
target	0	10/0/14/0.0	tgt	CLAIMED	DEVICE	
disk	0	10/0/14/0.0.0	sdisk	CLAIMED	DEVICE	TEAC CD-532E-B
target	0	10/0/14/0.7	tgt	CLAIMED	DEVICE	
ctl	0	10/0/14/0.7.0	sctl	CLAIMED	DEVICE	Initiator
ba	1	10/0/14/1	superio	CLAIMED	BUS_NEXUS	PCI Core I/O Adapter
tty	0	10/0/14/1/1	asio0	CLAIMED	INTERFACE	Built-in RS-232C
tty	1	10/0/14/1/2	asio0	CLAIMED	INTERFACE	Built-in RS-232C
ext_bus	1	10/0/14/1/3	SCentIf	CLAIMED	INTERFACE	Built-in Parallel Interface
siopc	0	10/0/14/1/4	siofdc	CLAIMED	INTERFACE	Built-in Floppy Drive
floppy	0	10/0/14/1/4.1	sioflop	CLAIMED	DEVICE	HP_PC_FDC_FLOPPY
usb	0	10/0/14/2	hcd	CLAIMED	INTERFACE	Built-in USB Interface
usbhub	0	10/0/14/2.1	hub	CLAIMED	DEVICE	USB Root Hub
ext_bus	2	10/0/15/0	c720	CLAIMED	INTERFACE	Ultra Narrow Single-Ended SCSI
target	1	10/0/15/0.7	tgt	CLAIMED	DEVICE	
ctl	1	10/0/15/0.7.0	sctl	CLAIMED	DEVICE	Initiator
ext_bus	3	10/0/15/1	c720	CLAIMED	INTERFACE	Ultra2 Wide LVD SCSI
target	2	10/0/15/1.6	tgt	CLAIMED	DEVICE	
disk	0	10/0/15/1.6.0	sdisk	CLAIMED	DEVICE	SEAGATE ST39102LC
target	3	10/0/15/1.7	tgt	CLAIMED	DEVICE	
ctl	2	10/0/15/1.7.0	sctl	CLAIMED	DEVICE	Initiator
ba	2	10/1	ROPEtoPCI	CLAIMED	BUS_NEXUS	PCI Bus Bridge - ROPEtoPCI
ba	3	10/2	ROPEtoPCI	CLAIMED	BUS_NEXUS	PCI Bus Bridge - ROPEtoPCI
ba	4	10/4	ROPEtoPCI	CLAIMED	BUS_NEXUS	PCI Bus Bridge - ROPEtoPCI

ba	5	10/6	ROPEtoPCI CLAIMED	BUS_NEXUS	PCI Bus Bridge - ROPEtoPCI
processor	0	32	processor CLAIMED	PROCESSOR	Processor
processor	1	34	processor CLAIMED	PROCESSOR	Processor
memory	0	49	memory CLAIMED	MEMORY	Memory

Assigning Ultra Narrow Single-Ended SCSI Device IDs

You can determine which Ultra Narrow Single-Ended SCSI (NSE SCSI) devices are currently in use by reviewing the output from the `ioscan` command discussed above and looking under the “H/W Path” heading. The entry `10/0/15/0` is the built-in Ultra Narrow Single-Ended SCSI bus. For devices connected to the built-in Ultra Narrow Single-Ended SCSI bus, such as disks, the number between the two decimals and after the third “/” in the hardware path specifies the SCSI ID for that device. For example, a hardware path of `10/0/15/0.2.0` specifies a NSE SCSI device at SCSI ID 2. Here is the break down of the hardware path:

```

SCSI device  10/0/15/0.2.0
NSE SCSI    10/0/15/0.2.0
SCSI ID 2   10/0/15/0.2.0

```

CAUTION

Do not use SCSI device ID 7 for any device. It is reserved for the built-in SCSI bus controller.

Assigning Ultra2 Wide Low-Voltage Differential SCSI Device IDs

You can determine which Ultra2 Wide Low-Voltage Differential SCSI (LVD SCSI) devices are currently in use by reviewing the output from the `ioscan` command discussed above and looking under the “H/W Path” heading. The entry `10/0/15/1` is the built-in Ultra2 Wide Low-Voltage Differential SCSI bus. For devices connected to the built-in Ultra2 Wide Low-Voltage Differential SCSI bus, such as disks, the number between the two decimals and after the third “/” in the hardware path specifies the SCSI ID for that device. For example, a hardware path of `10/0/15/1.5.0` specifies a LVD SCSI device at SCSI ID 5. Here is the break down of the hardware path:

SCSI device	<u>10/0/15</u> /1.5.0
LVD SCSI	10/0/15/ <u>1</u> .5.0
SCSI ID 5	10/0/15/1. <u>5</u> .0

CAUTION

Do not use SCSI device ID 7 for any device. It is reserved for the built-in SCSI bus controller.

Connecting to the SCSI Ports

This section describes how to connect to the system SCSI ports (Ultra Narrow Single-Ended and Ultra2 Wide Low-Voltage Differential).

System SCSI Port Connection

The system contains two SCSI connectors:

- Ultra Narrow Single-Ended SCSI (NSE SCSI) connector
- Ultra2 Wide Low-Voltage Differential SCSI (LVD SCSI) connector

The illustration below shows the two SCSI connectors. SCSI cables connect to these ports with a high-density thumbscrew connector.

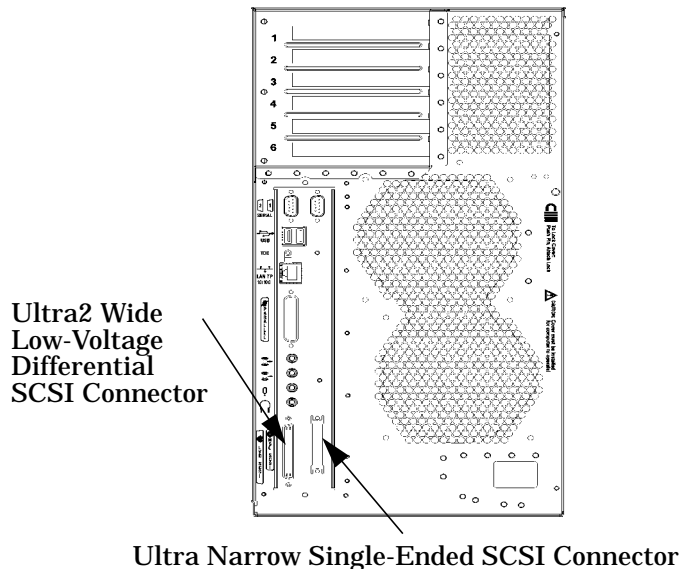

NOTE

It is necessary to put a terminator on unused SCSI connectors on the back panel, or the last device connected to the SCSI bus. Terminators are shipped with the system. Be sure to use a NSE SCSI terminator for the NSE SCSI bus and an LVD SCSI terminator for the LVD SCSI bus.

SCSI Connections
Connecting to the SCSI Ports

Here are the topics covered in this document:

- System Unit Front Panel
- Left Side Panel of the System Unit
- System Unit Power Supply
- I/O Cards
- System Unit Fans
- Removable Media Devices
- Hard Disk Drives
- Memory Cards
- Changing Your Monitor Type

The instructions in this chapter assume you are using the HP-UX 10.20 or 11.0 operating system with the HP CDE interface. Information for the HP CDE interface can be found in the HP CDE Getting Started Guide.

CAUTION

Always wear a properly grounded wrist strap when reconfiguring your computer with internal devices. For details on electrostatic discharge, read the section “Electrostatic Discharge (ESD) Precautions” in the preface of this document.

WARNING

Always unplug the system unit power cord from the electrical outlet or power source before opening the system unit.

Use the following tools to remove or replace hardware parts when changing your configuration:

- Light-duty flat blade screwdriver with 150mm (6 inch) long shaft
- T-10 and T-15 Torx drivers. Note that the screws these drivers are used on have a recessed slot for use by flat-bladed screwdrivers.
- Needle-nose pliers

NOTE

Many of the HP-UX commands in this chapter will require that you become superuser (`root`). If you cannot log in as `root`, contact your system administrator.

System Unit Front Panel

This section explains how to open and close the system unit's front panel.

Opening the System Unit Front Panel

Perform the following steps to open the system unit.

1. Power off the system, and unplug the system unit power cord from the electrical outlet. Note that when you press the system power switch, the system automatically performs a shutdown -q.
2. Attach the static-grounding wrist strap by following the instructions on the package. Attach the sticky end of the wrist strap to bare metal on the back panel of the system unit.
3. Unlatch the front panel (also known as the front bezel) by pressing in on the two latch buttons located on the right side of the front panel. See Figure 5-1. If the front panel does not open, you may have to locate the front panel key and unlock it.

Figure 5-1 Opening the Front Panel

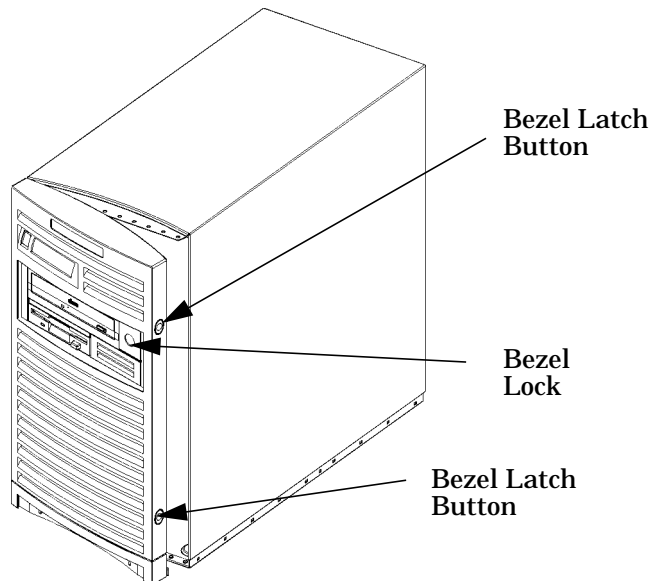

4. Swing the panel outward on its left snap hinges until the panel comes free and place the front panel in a location where it cannot get broken.

Closing the System Unit Front Panel

Perform the following steps to close the system unit.

1. Locate the hinges on the left side of the front panel, and insert them into the holes located along the left edge of the system unit.
2. Rotate the front panel inward until you hear the two latch buttons snap in place. The front panel is now closed. If there is a need to lock the front panel, use the system unit keys that came with your system to lock the panel. These keys are located inside the front bezel below the floppy disk drive.
3. Plug in the system unit power cord, and power on the system.

Left Side Panel of the System Unit

This section explains how to open and close the left side panel of the system unit. This side panel will have to be opened whenever you need access to the internal components of the computer.

Opening the Left Side Panel of the System Unit

Perform these steps to open the left side panel.

NOTE

When you remove the left side panel, the system unit's safety interlock release pin will come out of the safety interlock switch and shutdown the system without performing the proper shutdown sequences. See Figure 5-2. Therefore, before taking the left side panel of your computer off, do a `reboot -h` or press the soft power switch on the front panel of your computer. Either of these actions will gracefully power down the system.

1. Power off the system, and unplug the system unit power cord from the electrical outlet.
2. Attach the static-grounding wrist strap by following the instructions on the package. Attach the sticky end of the wrist strap to bare metal on the back panel of the system unit.
3. Turn the computer around so its back is facing you. On the right edge of the computer, there are two T-15 Torx thumbscrews as shown in Figure 5-2. Remove the two T-15 Torx thumbscrews.

4. Grasp the back edge of the left side panel and rotate it outward approximately 30 degrees to the computer. Next, pull the panel toward you as shown in Figure 5-2. This releases the panel's top and bottom left side hook hinges from their hinge slots. See Figure 5-2.

Figure 5-2 **Opening the Left Side Panel of the System Unit**

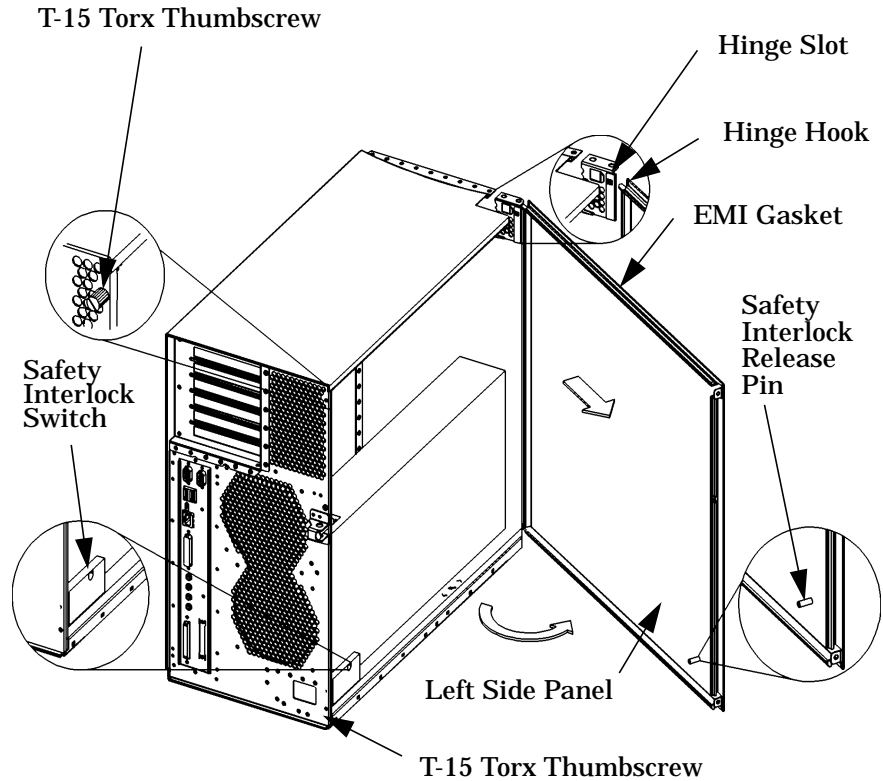

NOTE

The EMI gasket, as shown in Figure 5-2, must not be removed from the side panel.

Closing the Left Side Panel of the System Unit

Perform these steps to close the left side panel.

1. Hold the left side panel so that the top and bottom hinge hooks can be inserted into their hinge slots. See Figure 5-2. Note that the hinge slots are located on the far right edge of the system unit (using the back of the system unit as the reference).
2. Swing the back edge of the panel toward the system unit's back edge and press the outside edges of the side panel tightly against the system unit. This will ensure a tight seal of the EMI gaskets.
3. Secure the side panel in place with the two T-15 Torx thumbscrews you previously removed, and tighten them using 6 inch-pounds of torque.

System Unit Power Supply

This section will prove important to you as you begin to update your system unit. For example, you may need to install memory in your system unit. To do this, you need to position the power supply so you can get to the memory slots. This section will help you accomplish this task.

WARNING

To prevent injury, you need to unplug the system unit's power cord from the electrical outlet before servicing any components within the system unit.

Propping Up the Power Supply

To prop the power supply up, follow these steps:

1. Lay the system unit on its right side (using the front panel as your reference) and on a cushioned surface to avoid cosmetic damage to the system unit's exterior.
2. Open the left side panel of the system unit by following the procedure in the section "Opening the Left Side Panel of the System Unit" in this chapter.
3. Unscrew the two captive screws on the power supply chassis as shown in Figure 5-3 using a T-15 Torx driver.

Figure 5-3 Unscrewing the Power Supply Captive Screws

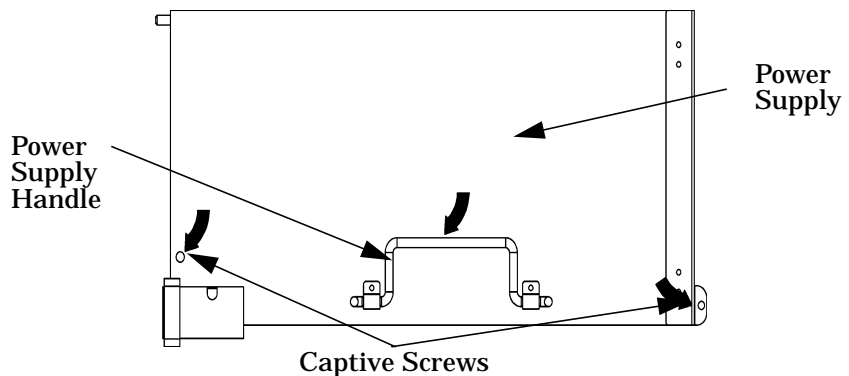

Changing Your Computer Hardware Configuration
System Unit Power Supply

4. Lift up on the power supply. The bail will automatically engage to hold up the power supply at approximately 90 degrees. See Figure 5-4.

Figure 5-4 Propping Up the Power Supply

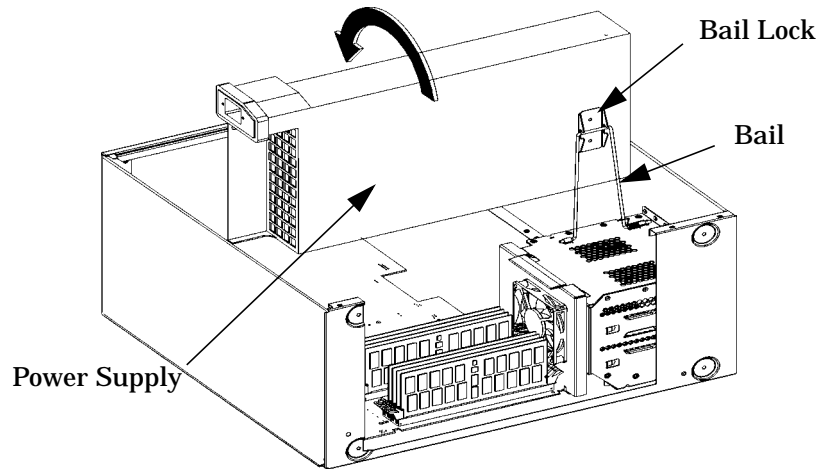

Closing the System Unit After Propping Up the Power Supply

Once you complete the task you set out to perform, you are ready to close the system unit. To close the system unit follow these steps:

1. Pull slightly back on the power supply until you are able to remove the bail from the bail lock. Using the power supply handle lower it downward into its original operating position. See Figure 5-3.
2. Tighten both captive screws in place as seen in Figure 5-3. Use a T-15 Torx driver and 6 inch-pounds of torque to tighten the screws.
3. Replace the left side panel of the system unit as shown in the section “Closing the Left Side Panel of the System Unit” in this chapter.

I/O Cards

Your B1000 and C3000 computer's PCI assembly has six slots. Slots 1 through 4 are full-size PCI slots. Slots 5 and 6 are half-size Peripheral Connect Interface (PCI) slots. See Figure 5-5 for a brief description of slot capabilities.

Figure 5-5 PCI Card Slot Numbering and Capabilities

SL1	64 Bit, 5.0V, 33MHz
SL2	Primary Graphics, 64 Bit, 3.3V, 66MHz
SL3	64 Bit, 5.0V, 33 MHz
SL4	Secondary Graphics, 64 Bit, 5.0V, 33 MHz
SL5	32 Bit, 5.0V, 33MHz
SL6	32 Bit, 5.0V, 33MHz

NOTE

To maintain optimum graphics performance, you should always use slot 2 (SL2) as your primary graphics card slot and slot 4 (SL4) as your secondary graphics card slot.

If you connect your monitor to a different graphics card slot, you will need to change the graphics path for that monitor. To do this read the section "Displaying and Setting the Monitor Type" in the chapter "The Boot Console Interface."

Note that the six I/O slots as seen from the back of the computer are labeled from top to bottom starting with one. See Figure 5-6.

Figure 5-6 I/O Slot Numbering

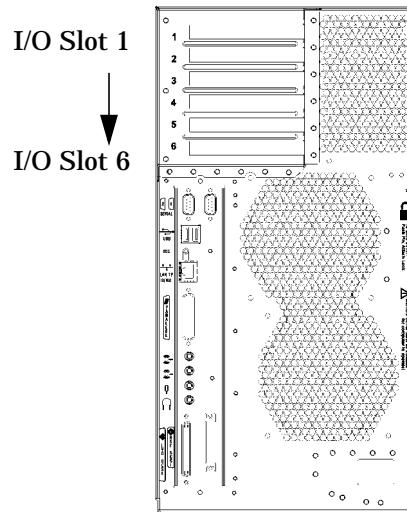

Removing I/O Cards

You will need a T-15 Torx driver or flathead screwdriver to remove the I/O slot bulkhead screws.

Here are the steps required for remove an I/O card from the system unit.

1. Power off the system, and unplug the system unit power cord from the electrical outlet. Note that when you press the system power switch, the system automatically performs a shutdown -q.
2. Open the side panel of the system unit as explained in the section “Opening the Left Side Panel of the System Unit” in this chapter.

3. Pull evenly in the direction of the arrow on both PULL tabs of the I/O card retainer to remove it. See Figure 5-7.

Figure 5-7 Removing the I/O Card Retainer

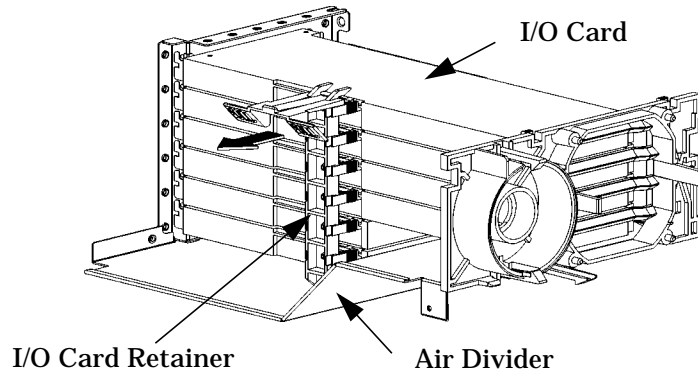

4. Locate the I/O card you want to remove and using a T-15 Torx driver remove the I/O card's bulkhead screw as shown in Figure 5-8.

Figure 5-8 Removing the I/O Card

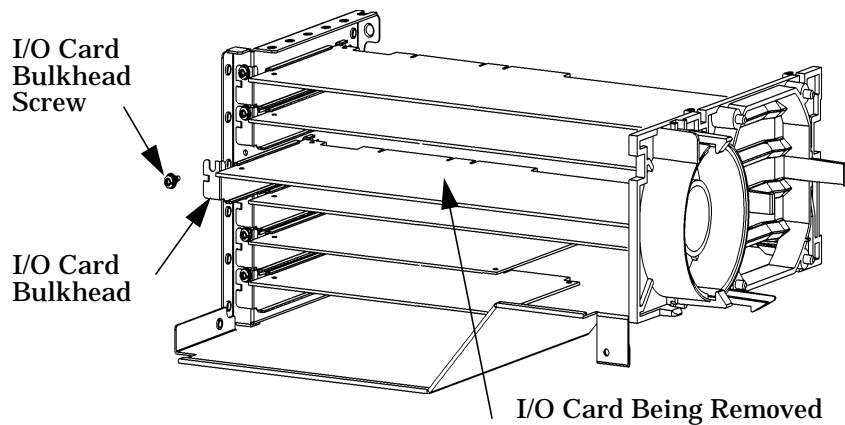

5. Pull evenly on the outside edges of the I/O card to remove it. See Figure 5-8.

Installing I/O Cards

To install an I/O card into your system unit, follow these steps.

NOTE

Slots two and four are the graphics card slots. The primary graphics card slot is slot number two and the secondary graphics card slot is slot number four.

1. Open the left side panel of the system unit as explained in the section “Opening the Left Side Panel of the System Unit” in this chapter.
2. Locate the appropriate slot for the I/O card that is to be installed. See Figure 5-5.
3. Unscrew the T-15 Torx screw and remove the bulkhead blank of the slot you have chosen. If no blank is present, you may skip to step four.
4. Pull evenly in the direction of the arrow on both PULL tabs of the I/O card retainer to remove it. See Figure 5-7.
5. Insert the I/O card into the slot you have chosen with the bulkhead appropriately positioned. See Figure 5-8. If the card is full length, the non-bulkhead end of the card should be placed in the I/O card guide. Press firmly and evenly on the I/O card until it is in the connector. Screw the T-15 Torx screw into the I/O card’s bulkhead using 6 inch-pounds of torque. This will secure the I/O card.
6. Replace the I/O card retainer by placing the bottom retainer hook in the slot on the air divider and the clips on the PULL tabs into their slots on the chassis wall. See Figure 5-7.
7. Close the left side panel of the system unit by following the procedure in the section “Closing the Left Side Panel of the System Unit” in this chapter.

System Unit Fans

Your system unit has several fans that are used to cool various areas within the unit. See Figure 5-9 for fan area locations. Since you are allowed only to remove the hard disk drive fan, this section just covers that task.

Figure 5-9 Fan Cooling Areas for the System Unit

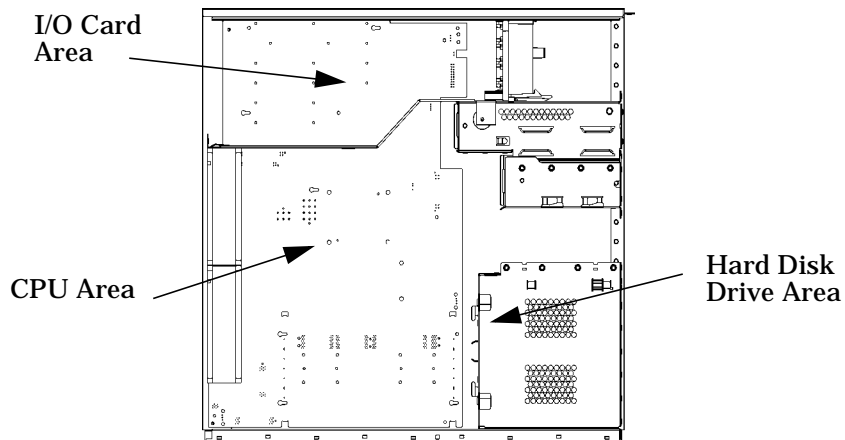

CAUTION

If one of the fans in the fan areas shown in Figure 5-9 is not working as indicated by an LCD error message, you need to call your local Hewlett-Packard support representative. Continuing to operate your system unit with a bad fan will cause damage to the system unit. To determine the fan that needs to be replaced, read Chapter 7 of this document.

Removing the Fan from the Hard Disk Drive Area

This section provides the procedure for removing the cooling fan from the back of the hard disk drive chassis. To remove memory cards, you will need to remove this fan.

To remove the fan from the hard disk drive chassis, follow these steps:

1. Lay the system unit on its side and on a cushioned surface to avoid cosmetic damage to the system unit's exterior.
2. Remove the system unit's side panel. See the section "Opening the Left Side Panel of the System Unit" in this chapter.
3. Prop up the power supply. See the section "Propping Up the Power Supply" in this chapter.

4. Lift up on the handle of the fan bracket to remove the fan. See Figure 5-10. As you lift up on the fan bracket, the top alignment tabs will be removed from their hard disk drive alignment screws, and the bottom alignment tabs will be removed from their alignment holes allowing the fan to be taken out of the system unit. If you are removing the hard disk drive fan to get access to the memory cards, you do not need to unplug the fan's power cable. Once the hard disk drive fan is removed, place it on top of the hard disk drive chassis.

Figure 5-10 Removing the Fan from the Hard Disk Drive Chassis

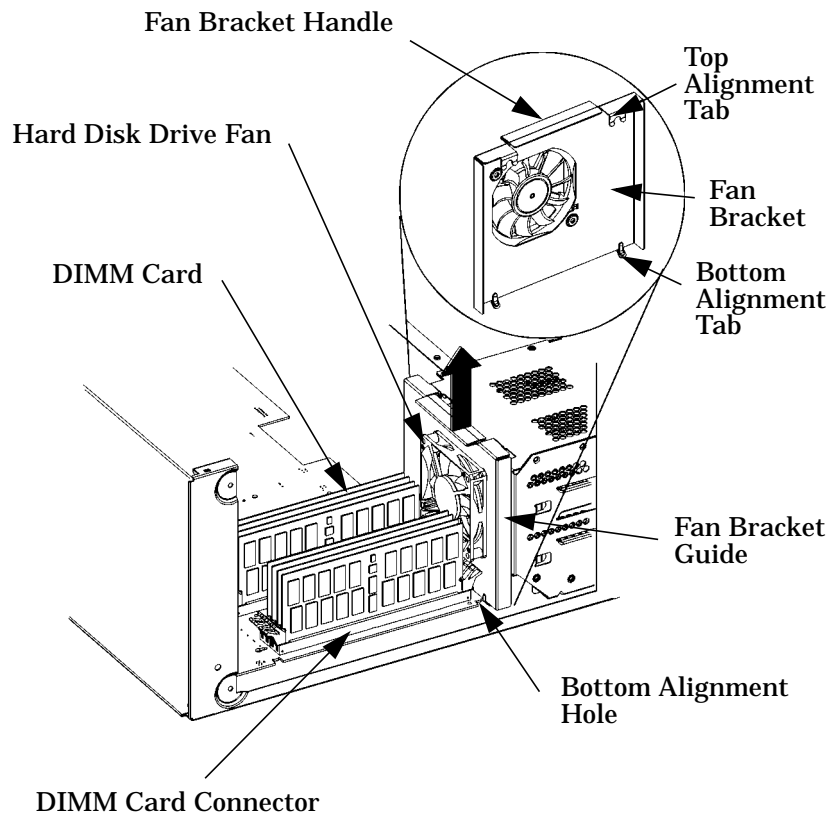

Replacing the Hard Disk Drive Fan

To replace the bracket and fan, follow these steps:

1. Position the fan bracket so that the top alignment tabs will fit around the two hard disk drive alignment screws, and the bottom alignment tabs can slide down into their alignment holes as shown in Figure 5-10. Once the tabs are properly aligned, slide them into place.
2. Close the system unit as explained in the section “Propping Up the Power Supply” in this chapter.

Removable Media Devices

There are only two internal removable media devices allowed in a B Class and C Class computer:

- CD drive
- 3.5-inch floppy disk drive.

The procedures provided in the subsequent sections explain how to install and remove removable media devices.

Installing a CD Drive

Install the CD drive by following the procedure covered in this section.

WARNING

Turn the system unit off and unplug the power cord before installing the CD drive.

Note that if you ordered your system unit with a CD drive from the factory, you will not need to set any jumpers on the back of your CD drive, as they are set at the factory. However, if you bought a new CD drive to install in your system, you will have to make sure that the master/slave/CSEL jumper is set in the CSEL position. Since different manufacturers of CD drives have different locations for the CSEL jumper, look at the documentation that comes with your CD drive for the proper location of this jumper.

CAUTION

CD drives are susceptible to mechanical and electronic shock. When handling the drive, always wear the static-grounding wrist strap that came in the CD drive kit. Always handle the drive carefully.

1. Perform the procedures in the sections “Opening the System Unit Front Panel” and “Opening the Left Side Panel of the System Unit.” The front panel needs to be opened so you can insert the CD drive into its proper location in the chassis. The left side panel needs to be

opened so you can get to the CD drive's audio, ATAPI and power connectors.

2. Remove the CD drive bay's rear cover by unscrewing the T-15 Torx/slotted screw as shown in Figure 5-11. Note that the CD drive's rear cover is located on the rear of the removable media chassis inside the system unit. Push the cover handle away from the rear of the removable media chassis approximately one inch. Next pull the cover handle toward you. The audio, ATAPI and power cables are now accessible to you.

Figure 5-11 Removing the CD Drive Bay's Rear Cover

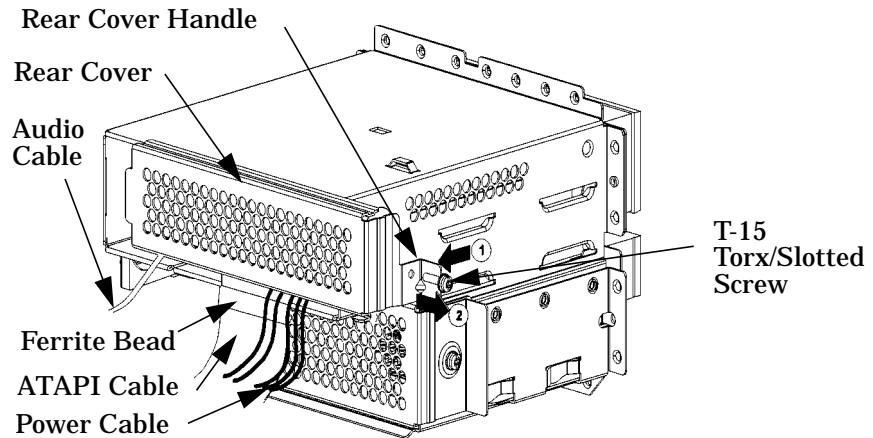

3. Rotate the system unit around until you see the front of the unit as shown in Figure 5-12.

Figure 5-12 Front of System Unit with the Front Panel Removed

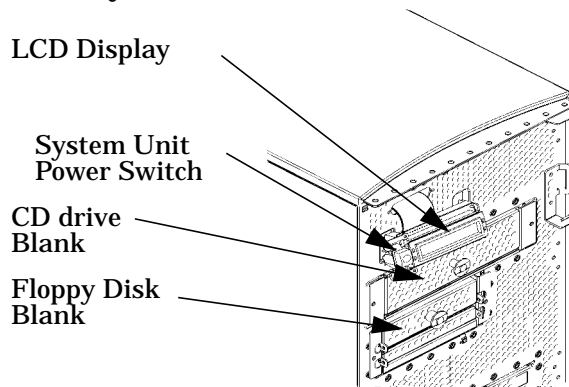

4. Remove both CD drive bracket screws (T-15 Torx/slotted screws) and pull the CD drive bracket out of the chassis assembly as shown in Figure 5-13. Next remove the four CD drive blank filler screws (T-10 Torx/slotted screws) as shown in Figure 5-13 and remove the blank filler from the bracket. You are now ready to mount the CD drive into the CD drive bracket. Note you will need the blank filler screws to mount the CD drive.

Figure 5-13 Removing the CD Drive Bracket and Blank

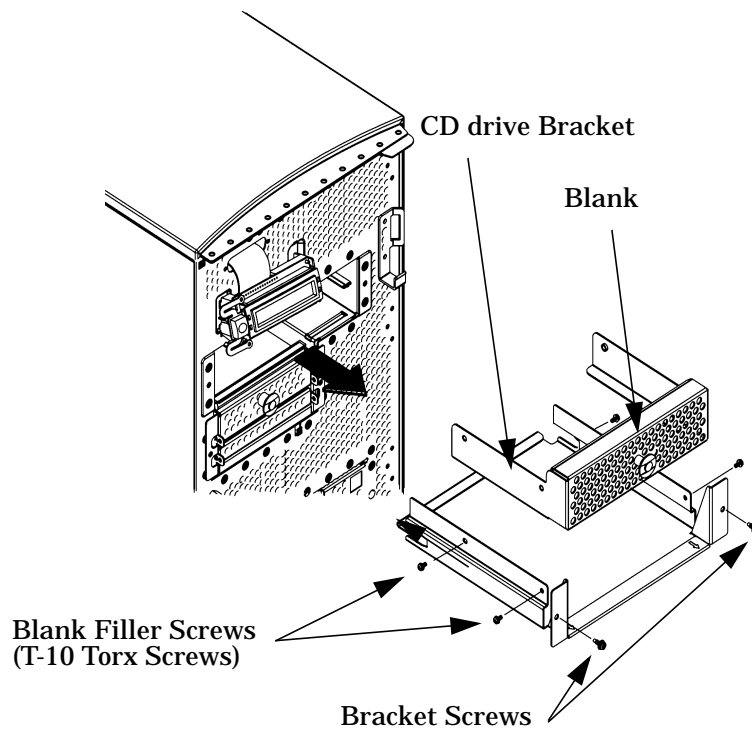

CAUTION

CD drives are susceptible to mechanical and electronic shock. When handling the drive, always wear the static-grounding wrist strap that came in the CD drive kit. Always handle the drive carefully.

5. Remove the CD drive from its shipping container and check to see that the jumper on the back of the CD drive is set to the C Select position. Using the four blank filler screws (T-10 Torx/slotted screws) that were just removed, mount the disk drive to the bracket as shown in Figure 5-14. The screws should be tightened using 6 inch-pounds of torque. Note that the CD drive should extend approximately one inch out from the front of the CD drive bracket.

Figure 5-14 Installing the CD Drive

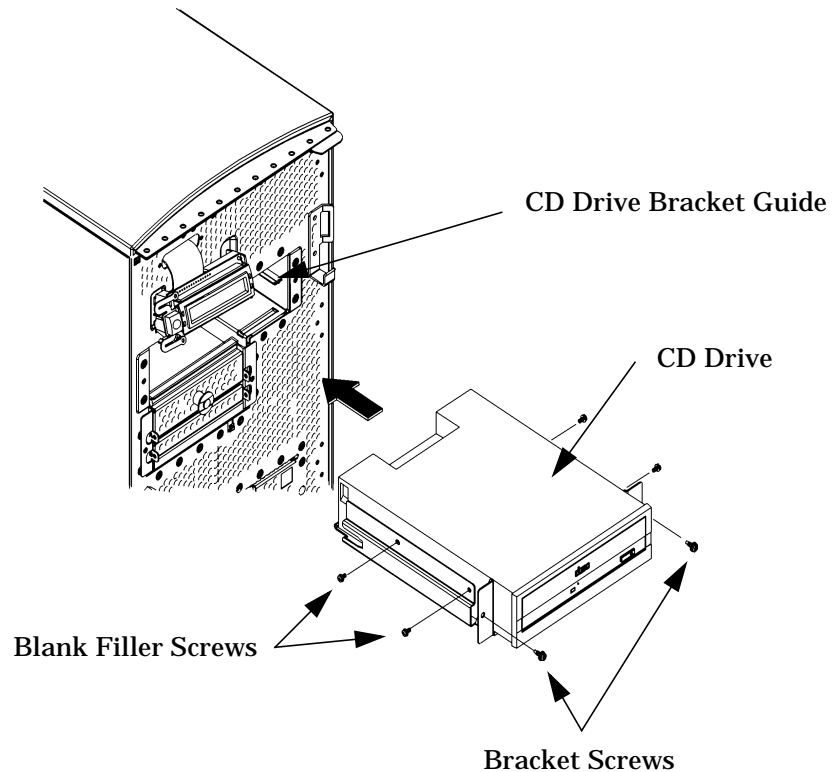

6. Slide the CD drive and its bracket into the system unit chassis as shown in Figure 5-14. There are runners on the side of each bracket and guides inside the CD drive chassis that will help the assembly to slide into place.

Changing Your Computer Hardware Configuration Removable Media Devices

7. Plug the audio, ATAPI and power cables into their appropriate connectors. Note that the connectors are keyed for proper insertion. See Figure 5-15. To help with plugging in the audio connector, you can pull its cable through the back of the CD drive chassis to the front of the CD drive chassis and connect it. Note that you should connect the audio cable first.

Figure 5-15 Plugging in the Audio, ATAPI and Power Cables

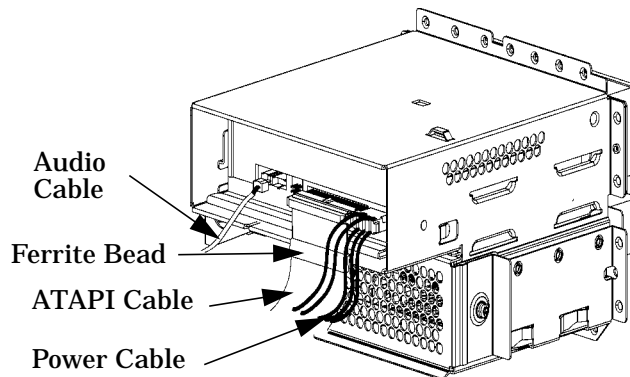

8. Tighten the two CD drive bracket screws as shown in Figure 5-16. The screws should be tightened using 6 inch-pounds of torque.

Figure 5-16 Tightening the Bracket Screws

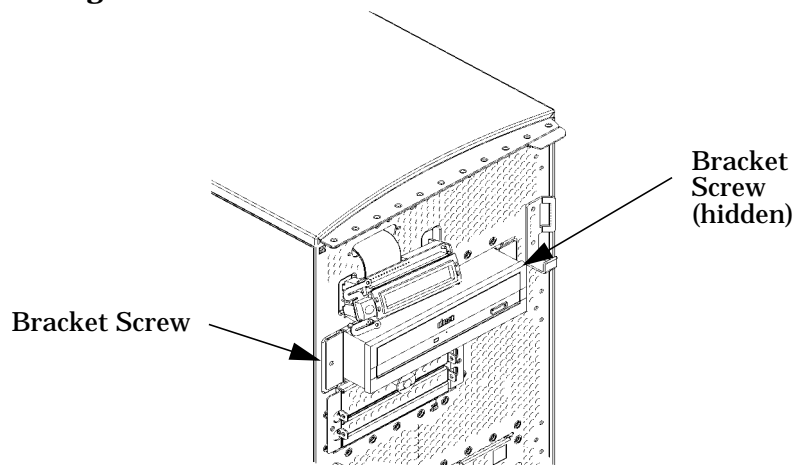

9. Make sure that the audio, ATAPI and power cables are positioned so that they come out of the bottom edge of the CD drive bay's rear cover. This edge is rounded to prevent cutting of the cables. See Figure 5-17. Next, secure the CD drive bay's rear cover using the T-15 Torx/slotted screw. The screw should be tightened using 6 inch-pounds of torque. When you replace the rear cover, the ferrite bead on the ATAPI cable must remain outside of the CD drive bay's rear cover.

Figure 5-17 Replacing the CD Drive Bay's Rear Cover

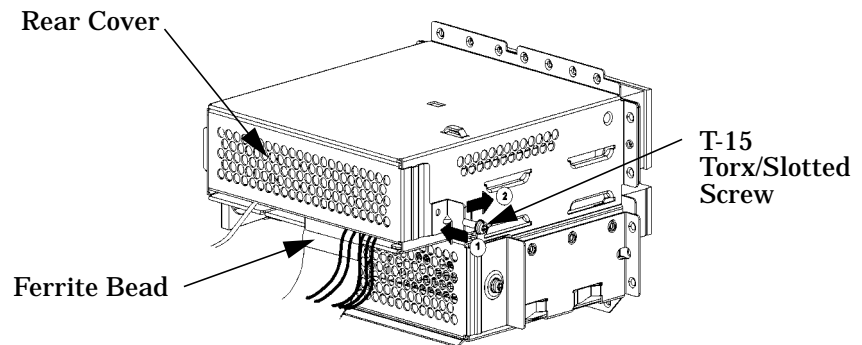

10. Remove the plastic CD drive blank from the computer's front panel.
11. Complete the installation of the CD drive by replacing the front and side panels of the system unit as explained in the sections "Closing the Left Side Panel of the System Unit" and "Closing the System Unit Front Panel" in this chapter. You should also make sure that all cables are positioned within the system unit so that they cannot be damaged.
12. Verify that the CD drive is recognized by the system. See the section "Verifying the CD Drive Operation" in the chapter "Using Your CD Drive."

Removing a CD Drive

This section explains how to remove a CD drive from your system unit.

WARNING

Turn the system unit off and unplug the power cord before removing the CD drive.

CAUTION

CD drives are susceptible to mechanical and electronic shock. When handling the drive, always wear the static-grounding wrist strap that came in the CD drive kit. Always handle the drive carefully.

1. Perform the procedures in the sections “Opening the System Unit Front Panel” and “Opening the Left Side Panel of the System Unit.” The front panel needs to be opened so you can remove the CD drive from the system chassis. The left side panel needs to be opened so you can get to the CD drive’s audio, ATAPI and power connectors.

2. Remove the CD drive bay's rear cover by unscrewing the T-15 Torx/slotted screw as shown in Figure 5-18. Note that the CD drive bay's rear cover is located on the back of the removable media chassis inside the system unit. Push the cover handle away from the back of the removable media chassis approximately one inch. Next pull the cover handle toward you. The audio, ATAPI and power cables are now accessible to you. Disconnect these cables from the CD drive.

Figure 5-18 Removing the CD Drive Bay's Rear Cover

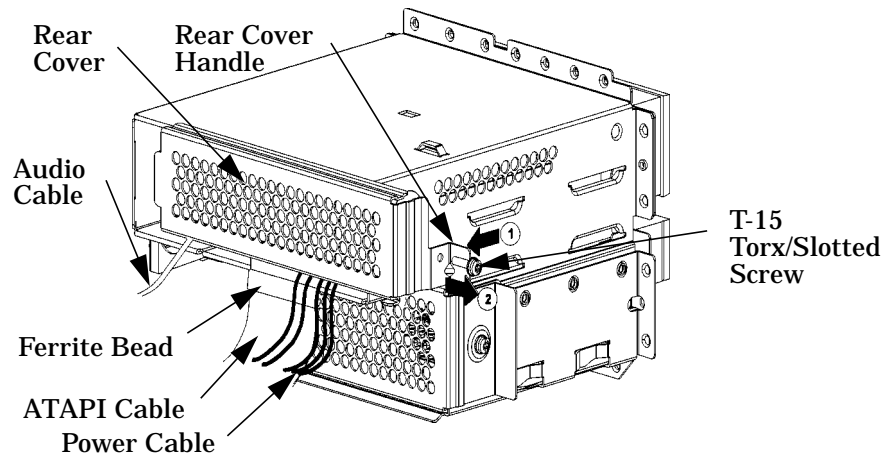

Changing Your Computer Hardware Configuration
Removable Media Devices

3. Rotate the system unit around until you see the front of the unit as shown in Figure 5-19.

Figure 5-19 Front of the System Unit with the Front Panel Removed

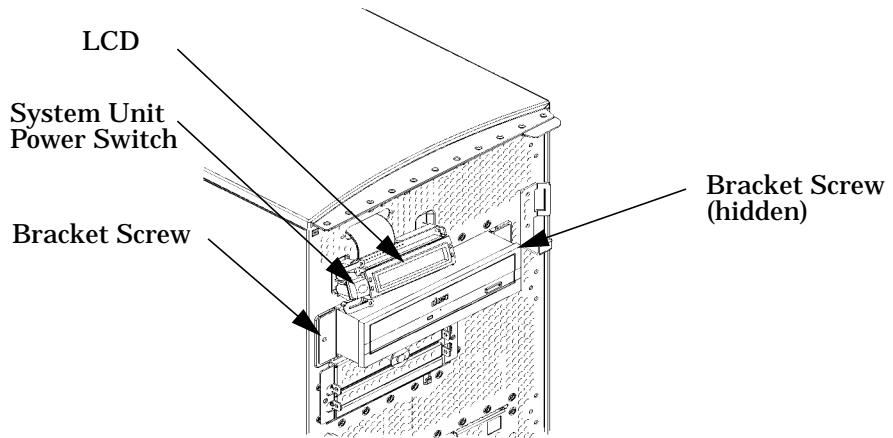

4. Remove both CD drive bracket screws (T-15 Torx/slotted screws) and pull the CD drive out of the chassis assembly as shown in Figure 5-20. Next remove the four CD drive mounting screws (T-10 Torx/slotted screws) as shown in Figure 5-20 and remove the CD drive from the bracket. You are now ready to attach the CD drive blank to the CD drive bracket.

Figure 5-20 Removing the CD Drive

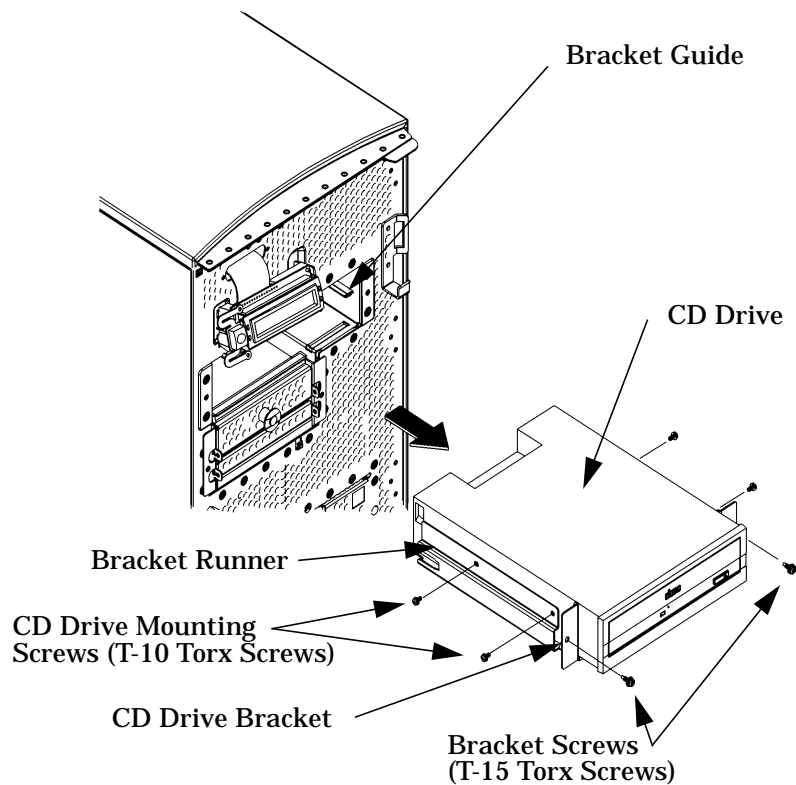

5. Insert the CD drive blank in the CD drive bracket and tighten the four CD drive mounting screws (T-10 Torx/slotted screws) using 6 inch-pounds of torque. This will secure the CD drive blank in place. Align the bracket runners and bracket guides and slide the CD drive blank and bracket into place. See Figure 5-21.

Figure 5-21 Installing the CD Drive Blank

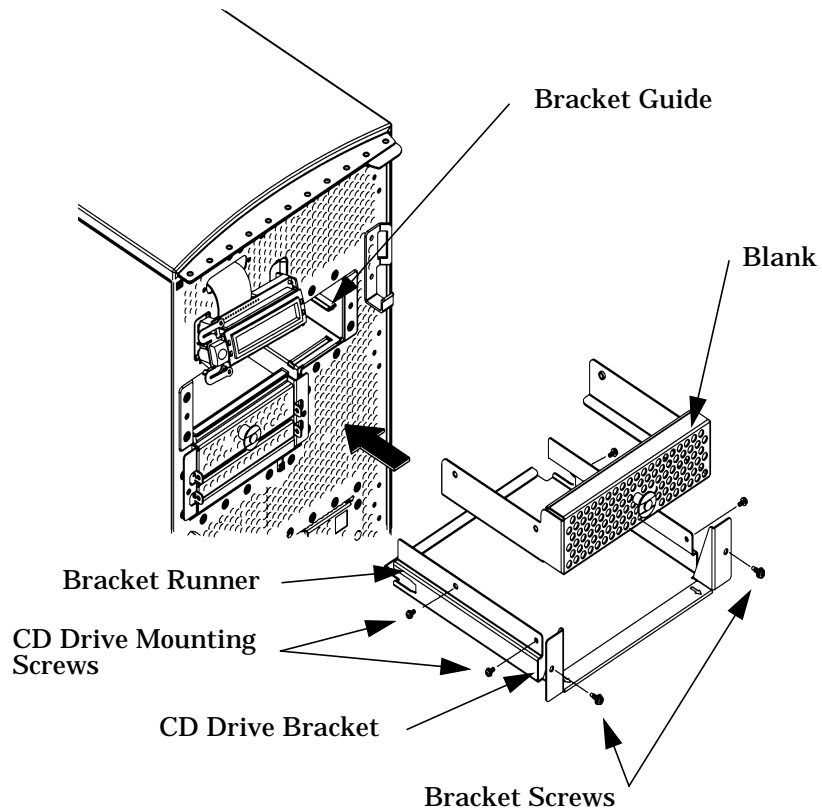

6. Tighten the two CD drive bracket screws as shown in Figure 5-22. These should be tightened using 6 inch-pounds of torque.

Figure 5-22 Tightening the Bracket Screws

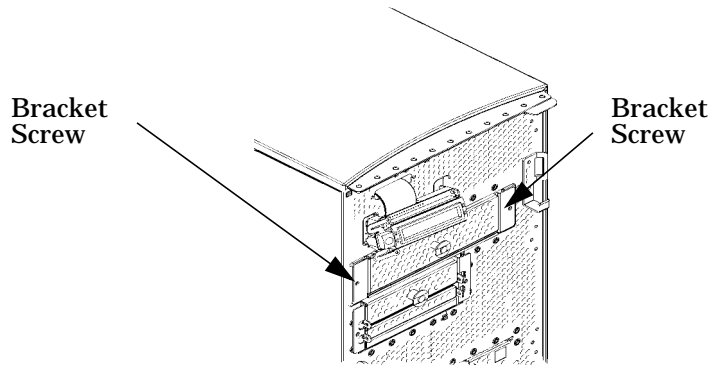

7. Place the audio, ATAPI and power cables inside the CD drive bay, and position the cables so that they go under the bottom edge of the CD drive bay's rear cover. The CD drive bay's rear cover's edge is rounded to keep you from cutting the cables. See Figure 5-23. Next, place the end opposite the rear cover handle into the cover slot, rotate it into place, and tighten the T-15 Torx/slotted screw using 6 inch-pounds of torque. This will secure the rear cover in place. See Figure 5-23. You have completed the removal of the CD drive.

Figure 5-23 Replacing the CD Drive Bay's Rear Cover

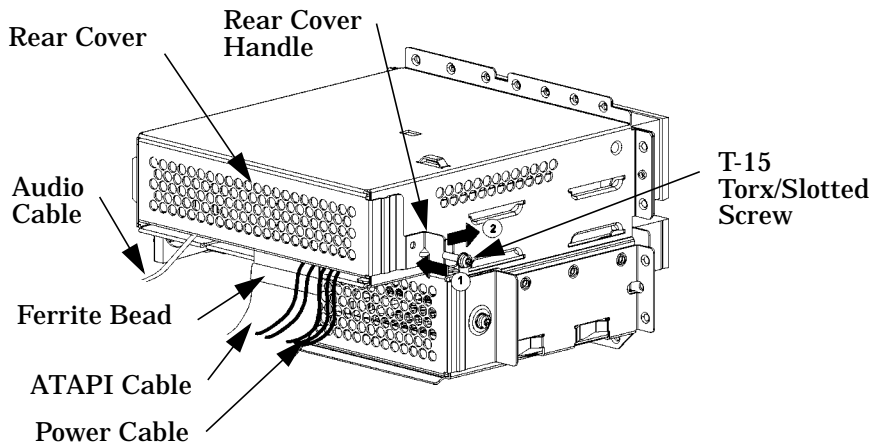

8. Replace the plastic CD drive blank in the computer's front panel.
9. Replace the left side panel and front panel of the system unit as explained in the sections "Closing the Left Side Panel of the System Unit" and "Closing the System Unit Front Panel" in this chapter.

Installing a Floppy Disk Drive

Install the floppy disk drive by following the procedure covered in this section. Note that there are no jumper settings required for the installation of the floppy disk drive.

WARNING

Turn the system unit off and unplug the power cord before installing the floppy disk drive.

CAUTION

Floppy disk drives are susceptible to mechanical and electronic shock. When handling the drive, always wear the static-grounding wrist strap that came in the floppy disk drive kit. Always handle the drive carefully.

1. Perform the procedures in the sections "Opening the System Unit Front Panel" and "Opening the Left Side Panel of the System Unit." The front panel needs to be opened so you can insert the floppy disk drive into its proper location in the chassis. The left side panel needs to be opened so you can get to the floppy's data connector and its power connector.

2. Remove the floppy disk drive bay's rear cover by unscrewing the T-15 Torx screw as shown in Figure 5-24. Note that the floppy disk drive bay's rear cover is located on the rear of the removable media chassis inside the system unit. Push the cover handle away from the rear of the removable media chassis approximately one inch. Next pull the cover handle toward you. The floppy data cable and power cable are now accessible to you.

Figure 5-24 Removing the Floppy Disk Drive Bay's Rear Cover

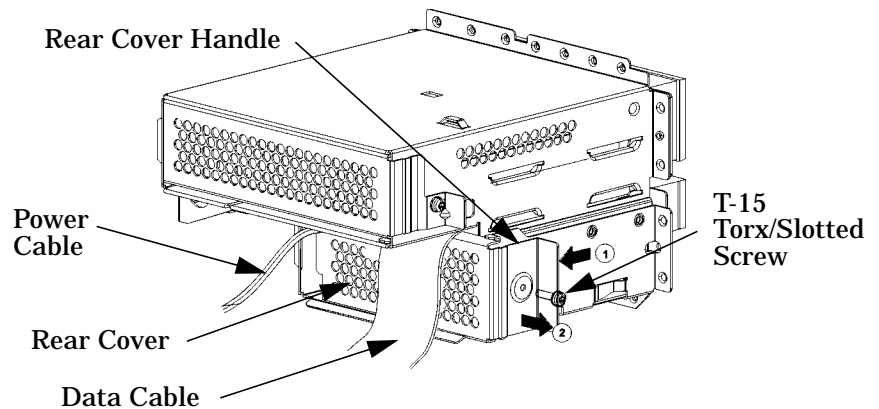

Changing Your Computer Hardware Configuration
Removable Media Devices

3. Rotate the system unit around until you see the front of the unit as shown in Figure 5-25.

Figure 5-25 Front of System Unit with the Front Panel Removed

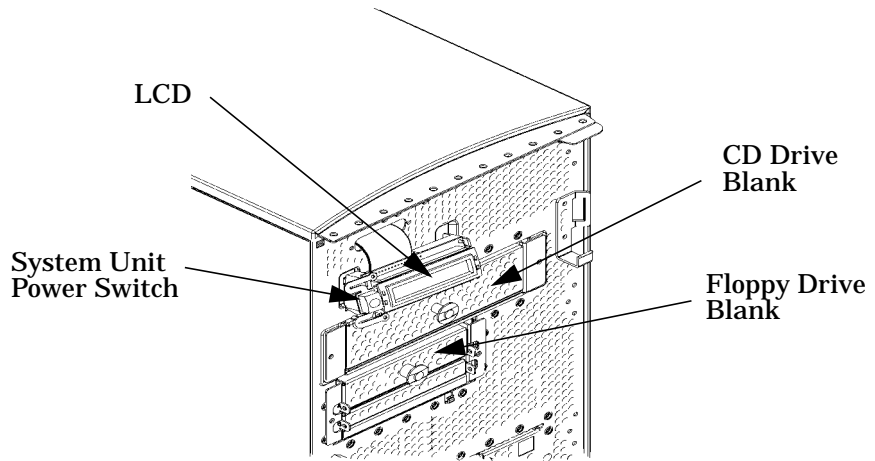

4. Remove both floppy disk bracket screws (T-15 Torx/slotted screws) and pull the floppy disk bracket out of the chassis assembly as shown in Figure 5-26. Next remove the four floppy disk blank filler screws (T-10 Torx/slotted screws) as shown in Figure 5-26 and remove the blank from the bracket. You are now ready to mount the floppy disk drive into the floppy disk bracket.

Figure 5-26 Removing the Floppy Disk Bracket and Blank

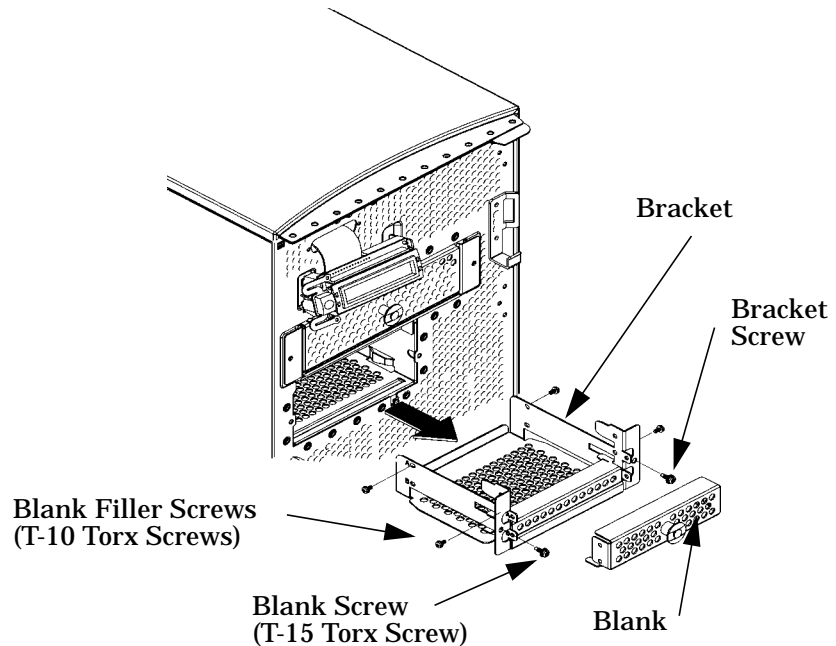

CAUTION

Floppy disk drives are susceptible to mechanical and electronic shock. When handling the drive, always wear the static-grounding wrist strap that came in the floppy disk drive kit. Always handle the drive carefully.

5. Remove the floppy disk drive from its shipping container. Using the four T-10 Torx/slotted blank filler screws, mount the disk drive to the bracket as shown in Figure 5-27. These filler screws require 6 inch-pounds of torque.

To help you properly install the floppy disk drive, you need to use the floppy disk drive holes labeled “A” on the bracket sides. The first T-10 Torx screws should be inserted through the tab holes of the floppy disk drive bracket that are located on the front part of both sides of the bracket. These T-10 Torx screws should then be screwed into the screw holes located on both sides of the floppy disk drive. These holes are located near the floppy disk drive’s front panel. The remaining T-10 Torx screws should be inserted through the holes labeled “A” at the back part of the floppy disk drive bracket. These screws should then be screwed into the rear screw holes located on both sides of the floppy disk drive. The front of the floppy disk drive should extend one inch from the front of the floppy disk drive bracket. See Figure 5-27.

Figure 5-27 Installing the Floppy Disk Drive

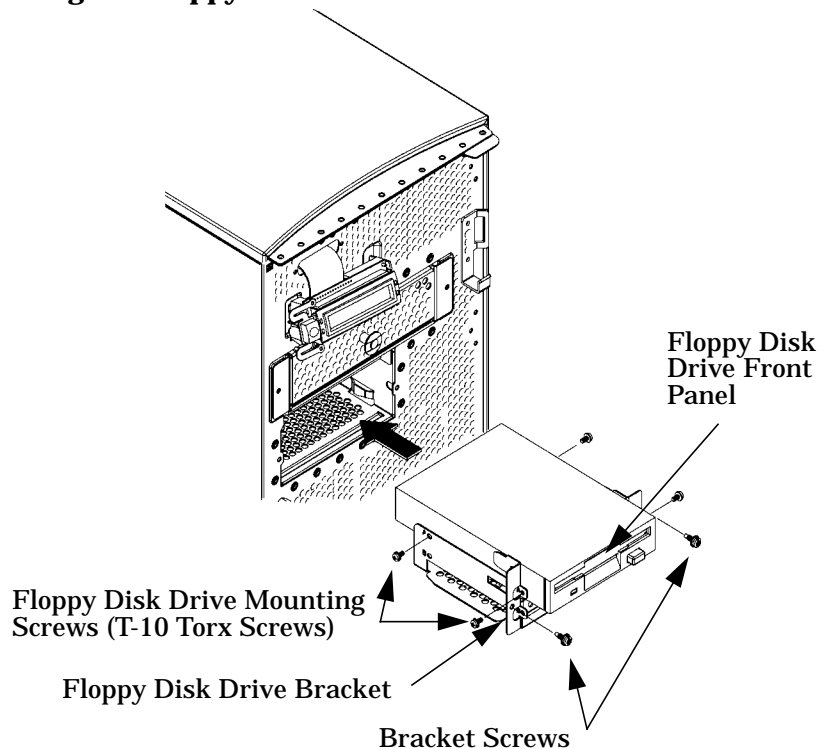

- Slide the floppy disk drive and its bracket into the system unit chassis as shown in Figure 5-27.
- Plug the floppy power cable into its connector. Next, plug the data cable into its connector. Note that the connectors are keyed for proper insertion. See Figure 5-28.

Figure 5-28 Plugging In the Floppy Data and Power Cables

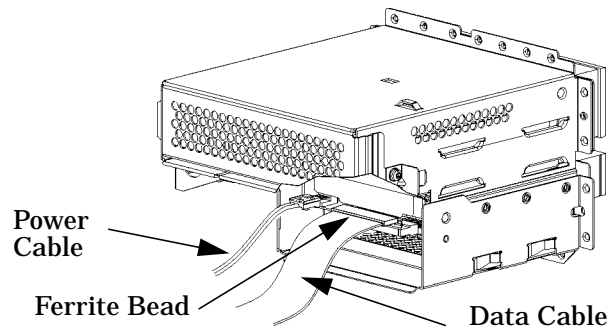

- Tighten the two floppy disk drive bracket screws as shown in Figure 5-29. You will need to use 6 inch-pounds of torque to tighten them.

Figure 5-29 Tightening the Bracket Screws

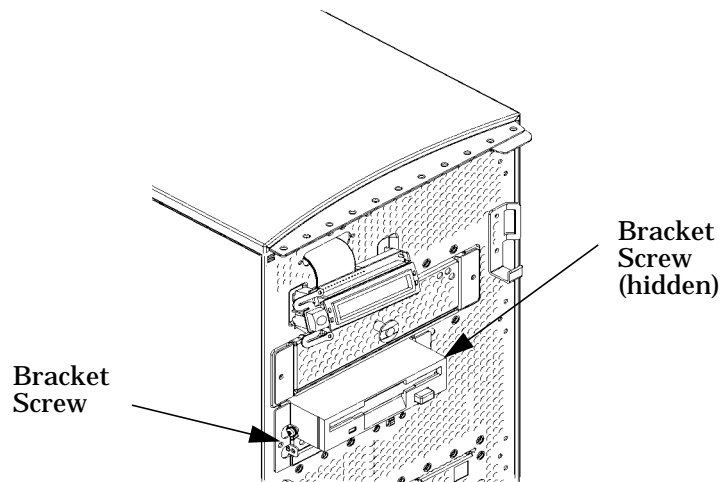

9. Make sure that the floppy data and power cables are positioned so that they come out of the top edge of the floppy disk drive bay's rear cover. This edge is rounded to prevent cutting of the cables. See Figure 5-30. Next, secure the floppy disk drive bay's rear cover using the T-15 Torx/slotted screw. You should tighten the screws using 6 inch-pounds of torque. When you replace the rear cover, the ferrite bead on the data cable must remain inside of the floppy disk drive bay's rear cover.

Figure 5-30 Replacing the Floppy Disk Drive Bay's Rear Cover

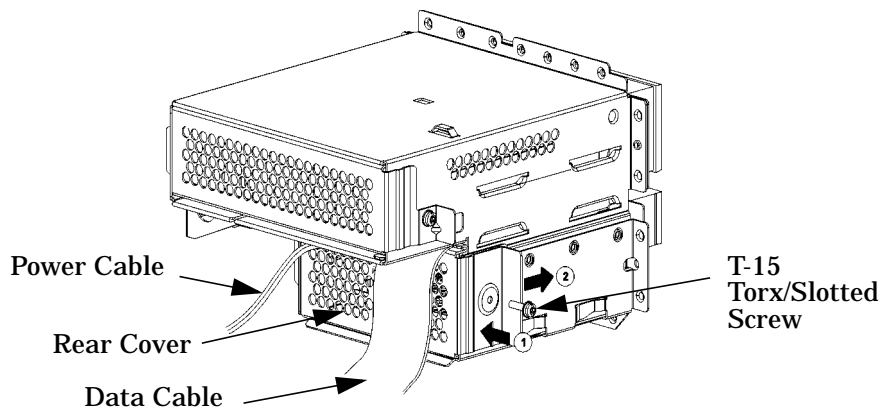

10. Remove the plastic floppy disk drive blank from the computer's front panel.
11. Complete the installation of the floppy disk drive by replacing the front and side panels of the system unit as explained in the sections "Closing the Left Side Panel of the System Unit" and "Closing the System Unit Front Panel" in this chapter. You should also make sure that all cables are positioned within the system unit so that they do not hang loosely. This will prevent damage to the cables.
12. Verify that the floppy disk drive is recognized by the system. See the section "Verifying the Floppy Drive Configuration" in the chapter "Using Your 3.5-Inch Floppy Disk Drive."

Removing a Floppy Disk Drive

This section explains how to remove a floppy disk drive from your system unit.

WARNING

Turn the system unit off and unplug the power cord before removing the floppy disk drive.

CAUTION

Floppy disk drives are susceptible to mechanical and electronic shock. When handling the drive, always wear the static-grounding wrist strap that came in the floppy disk drive kit. Always handle the drive carefully.

1. Perform the procedures in the sections “Opening the System Unit Front Panel” and “Opening the Left Side Panel of the System Unit.” The front panel needs to be opened so you can remove the floppy disk drive from the system unit chassis. The left side panel needs to be opened so you can get to the floppy disk drive’s data connector and its power connector.

Changing Your Computer Hardware Configuration

Removable Media Devices

2. Remove the floppy disk drive bay's rear cover by unscrewing the T-15 Torx/slotted screw as shown in Figure 5-31. Note that the floppy disk drive bay's rear cover is located on the rear of the removable media chassis inside the system unit. Push the cover handle away from the rear of the removable media chassis approximately one inch. Next pull the cover handle toward you. Remove the floppy data and power cables from their connectors.

Figure 5-31 Removing the Floppy Disk Drive Bay's Rear Cover

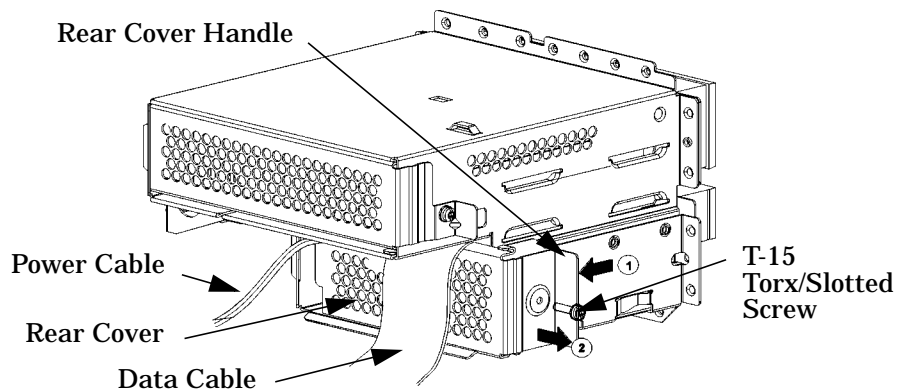

3. Rotate the system unit around until you can see the front of the unit as shown in Figure 5-32.

Figure 5-32 Front of System Unit with the Front Panel Removed

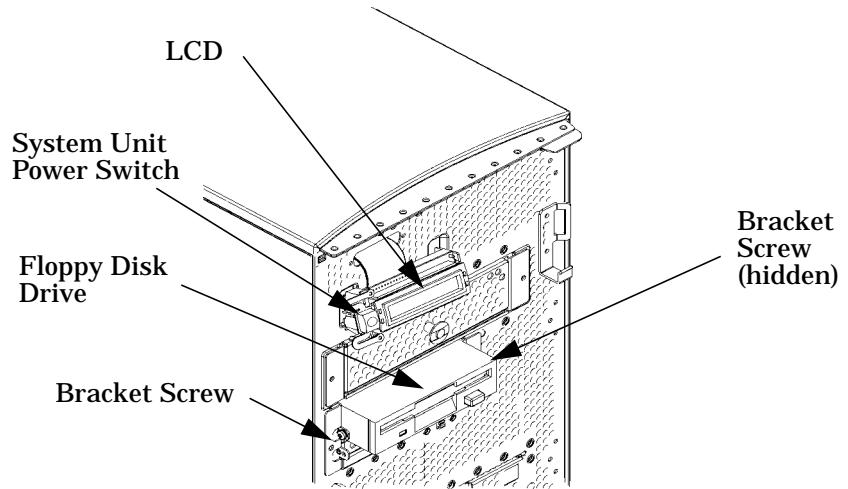

4. Remove both floppy disk bracket screws (T-15 Torx/slotted screws) and pull the floppy disk drive out of the chassis assembly as shown in Figure 5-33. Next remove the four floppy disk drive mounting screws (T-10 Torx/slotted screws) as shown in Figure 5-33 and remove the floppy disk drive from the bracket. You are now ready to attach the floppy disk drive blank to the floppy disk drive bracket.

Figure 5-33 Removing the Floppy Disk Drive

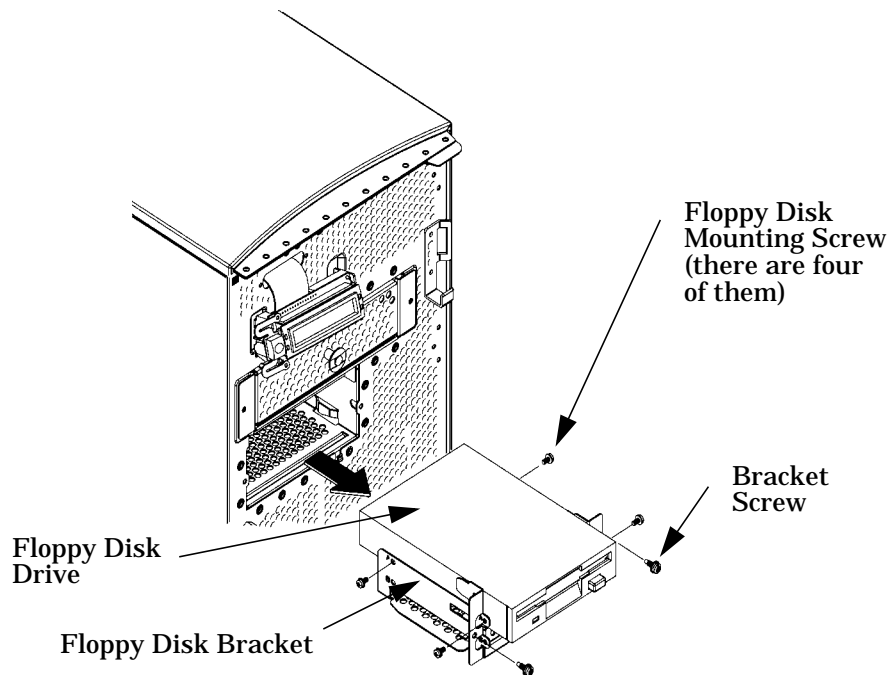

5. Place the floppy disk blank in the floppy disk bracket and insert the four floppy disk mounting screws (T-10 Torx/slotted screws) into the bracket and tighten them using 6 inch-pounds of torque. See Figure 5-34.

Figure 5-34 Installing the Floppy Disk Blank and Bracket

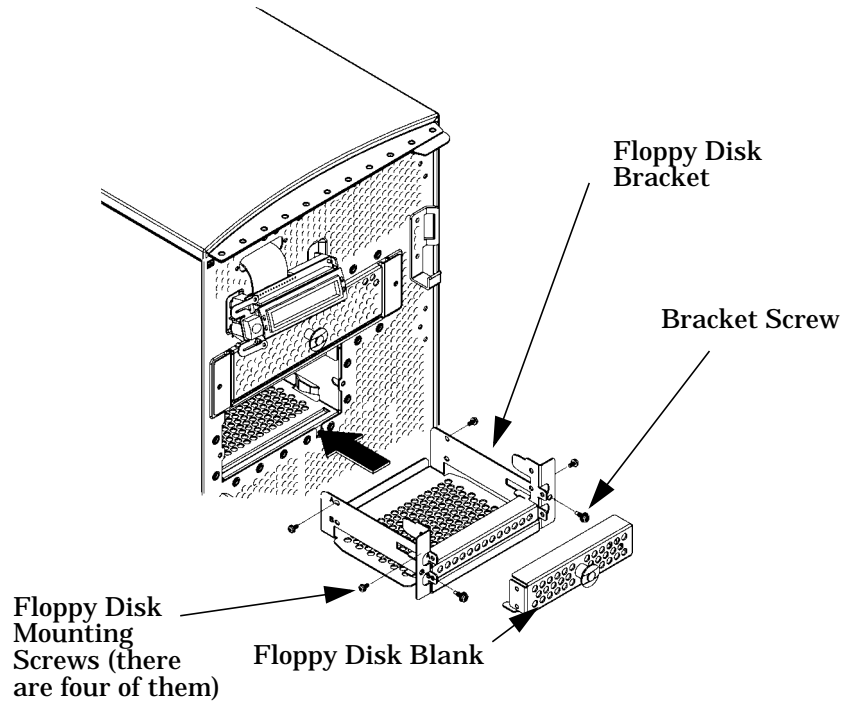

6. Slide the floppy disk blank and its bracket into the system unit chassis as shown in Figure 5-34.

Changing Your Computer Hardware Configuration Removable Media Devices

7. Tighten the two floppy disk bracket screws as shown in Figure 5-35. You will need to tighten them using 6 inch-pounds of torque.

Figure 5-35 Tightening the Bracket Screws

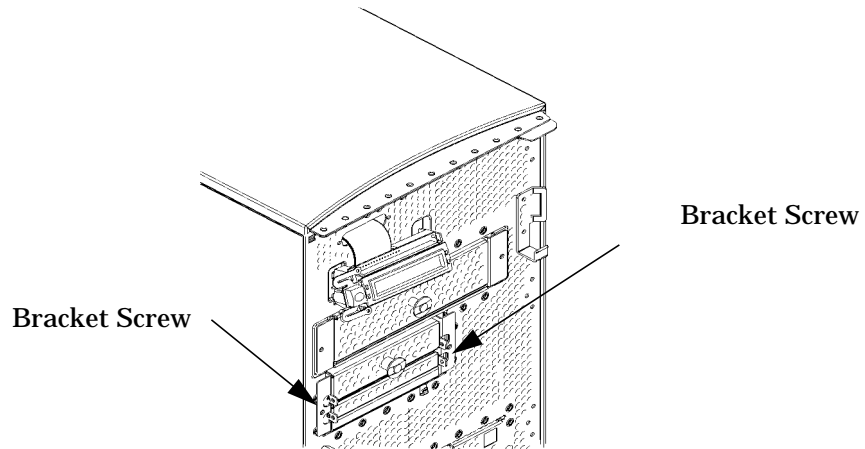

8. Make sure that the floppy data and power cables are positioned so that they come out of the top edge of the rear floppy disk drive bay's cover. This edge is rounded to prevent cutting of the cables. See Figure 5-36. Put the rear cover in place and tighten the T-15 Torx/slotted screw using 6 inch-pounds of torque.

Figure 5-36 Replacing the Rear Floppy Disk Drive Bay's Cover

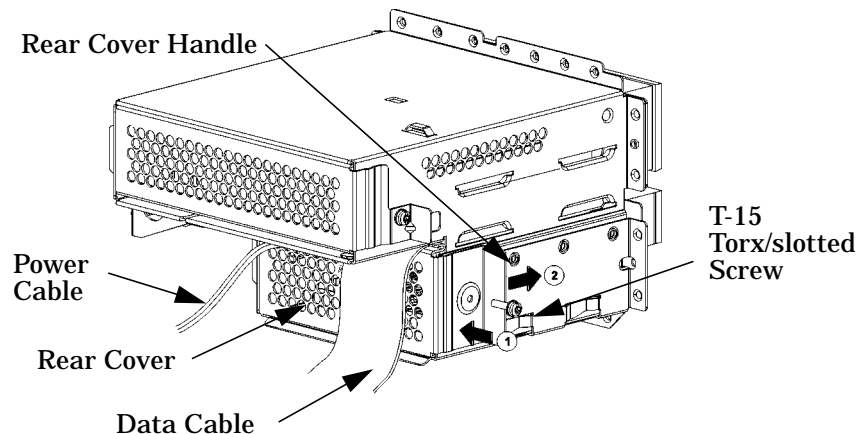

9. Replace the plastic floppy disk drive blank in the computer's front panel.
10. Complete the removal of the floppy disk drive by replacing the front and side panels of the system unit as explained in the sections "Closing the Left Side Panel of the System Unit" and "Closing the System Unit Front Panel" in this chapter. You should also make sure that all cables are positioned within the system unit so that they do not hang loosely. This will prevent damage to the cables.

Hard Disk Drives

This section describes how to install a hard drive in your computer and how to remove it from your computer. The first section details how to install a hard disk drive. The second section details how to remove a hard disk drive. The final section explains how to configure your hard disk after it is installed.

Your computer can have two internal hard disk drives. These internal hard disk drives are devices on the Ultra2 Wide Low-Voltage Differential SCSI bus. The hard disk drive that came with your computer was set to SCSI ID 6 on the Ultra2 Wide Low-Voltage Differential SCSI bus. If you are adding a second internal hard disk drive, the second hard disk drive will use SCSI ID 5 on the Ultra2 Wide Low-Voltage Differential SCSI bus. Note that the two slots for the hard disk drives have SCSI ID numbers 5 and 6 preassigned to them and SCSI ID 6 is the system disk. You will not be able to change these SCSI ID numbers.

CAUTION

Hard disk drives are susceptible to mechanical and electronic shock. When handling the drive, always wear the static-grounding wrist strap that came in the floppy disk drive kit. Always handle the drive carefully.

Installing a Hard Disk Drive

This procedure explains how to install your hard disk drive in the slot that has been preassigned SCSI ID 5. On internal hard disk drives, the slot determines the addressing. There are no cables required when installing a hard disk drive. Note that to install the hard disk drive, your computer must be turned off.

NOTE

If you are installing a hard disk drive, you will need to mount it and create a file system on it. This should be done after you have installed the hard disk drive.

To mount a hard disk drive and create a file system on it use the procedure provided in the section “Adding a Hard Disk Drive as a File System Using SAM” found in this chapter.

1. Open the front panel of your system unit using the instructions found in the section “Opening the System Unit Front Panel.” In the lower-right corner of the system unit as you face it, there are two hard drive slots. The slot on the right is the one discussed in this section. See Figure 5-37.

Figure 5-37 The Hard Drive Slots

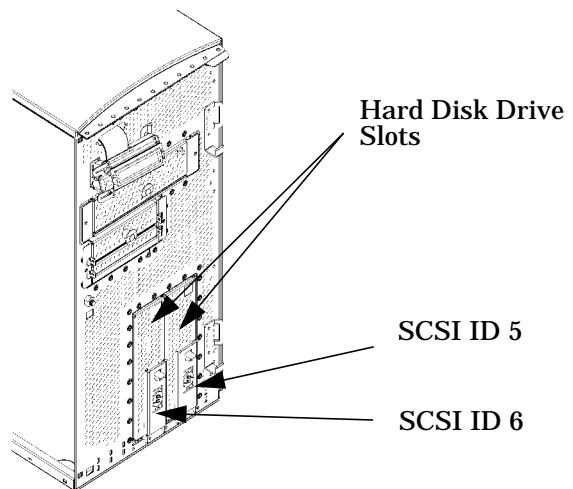

Changing Your Computer Hardware Configuration Hard Disk Drives

2. Open the hard drive slot by lifting the plastic release hook upward and pulling outward on the release lever as shown in Figure 5-38. As you pull outward on the release lever, the hard drive bracket will come out of its slot.

Figure 5-38 Removing the Hard Drive Bracket

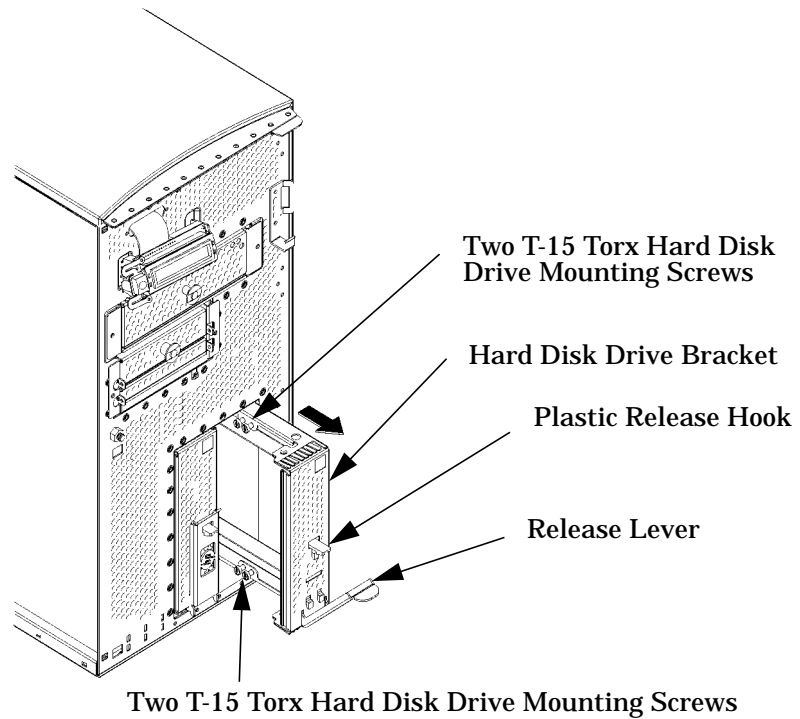

3. Mount the hard disk drive on the hard drive bracket using the four T-15 Torx shoulder screws that are stored on the mounting bracket. See Figure 5-38.

4. Insert the T-15 Torx Hard Disk Mounting Screws through the rubber mounting grommets and into the screw holes located on the sides of the hard disk drive. See Figure 5-39. You should tighten these screws using 6 inch-pounds of torque. Note that in order to screw the T-15 Torx screws into the sides of the hard disk drive you will have to have a T-15 Torx driver that is long enough to fit through the access holes on the sides of the hard disk drive bracket.

Figure 5-39 Inserting the Hard Disk Drive

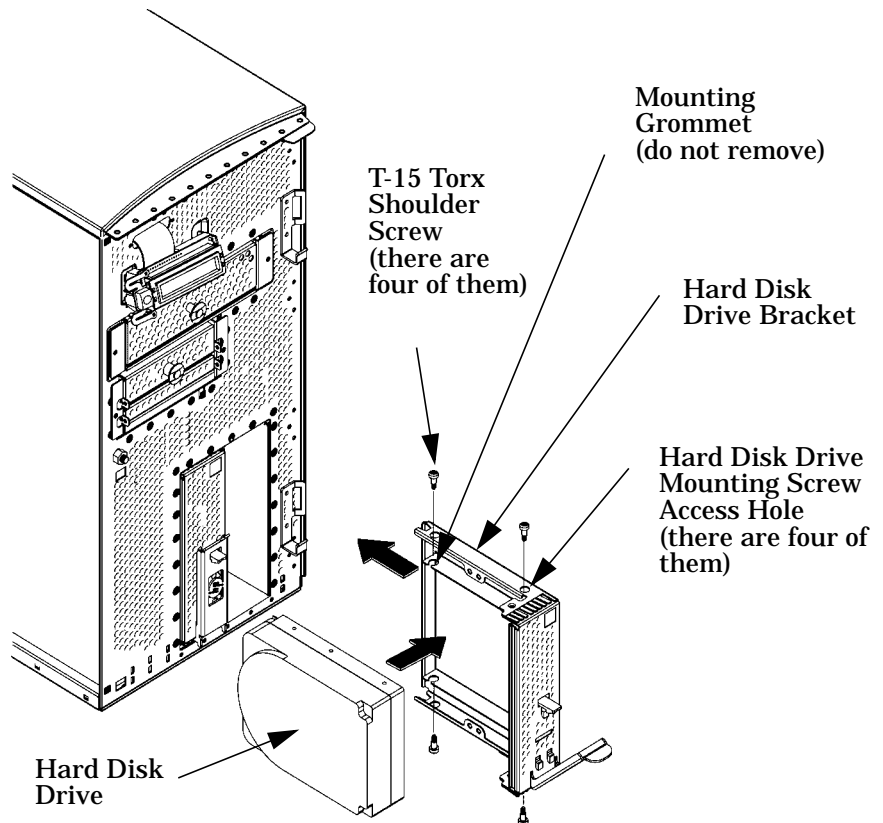

5. Slide the assembly into its hard drive slot, and push inward on the release lever until the front of the hard disk drive bracket is flush with the system unit and the lever snaps closed. The front panel should now be replaced as explained in the section “Closing the System Unit Front Panel” in this chapter.

Removing a Hard Disk Drive

This procedure explains how to remove your hard disk drive. Note that there are no cables for you to worry about when removing a hard disk drive. To remove a hard disk drive, your computer must be turned off.

NOTE

If you are removing a hard disk drive that has a mounted file system on it, you will need to unmount it. This should be done before you remove the hard disk drive.

To unmount a file system on a hard disk drive use the procedure provided in the section “Removing a Hard Disk Drive as a File System Using SAM” found in this chapter.

1. Open the front panel of your system unit using the instructions found in the section “Opening the System Unit Front Panel.” In the lower-right corner of the system unit as you face it, there are two hard drive slots. The slot on the right is the one discussed in this section. See Figure 5-40.

Figure 5-40 The Hard Drive Slots

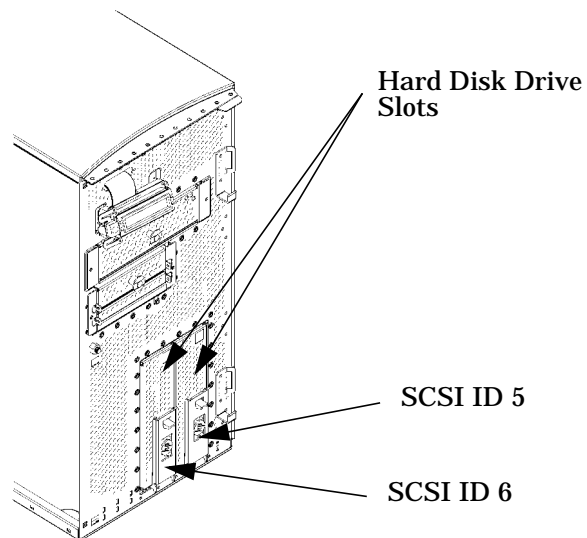

2. Open the hard disk drive slot by lifting the plastic release hook upward and pulling outward on the release lever as shown in Figure 5-41. As you pull outward on the release lever, the hard disk drive bracket will come out of its slot. Note that you should hold the hard disk drive bracket as well as the release lever to avoid dropping the hard disk drive when you remove it.

Figure 5-41 Removing the Hard Disk Drive

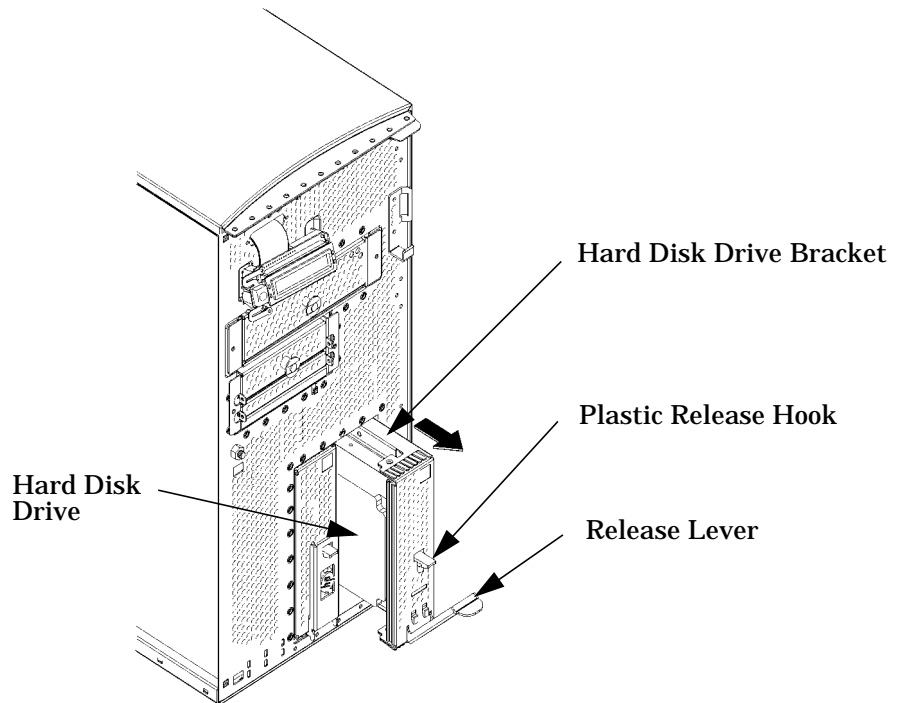

Changing Your Computer Hardware Configuration

Hard Disk Drives

3. Remove the four T-15 Torx shoulder screws from the hard disk drive and bracket. See Figure 5-42. You should be careful when removing the hard disk drive from its mounting bracket to avoid damaging it. Note that in order to remove the T-15 Torx screws from the sides of the hard disk drive you will have to have a T-15 Torx driver that is long enough to fit through the access holes on the sides of the hard disk drive bracket.

Figure 5-42 Removing the Hard Disk Drive from Its Bracket

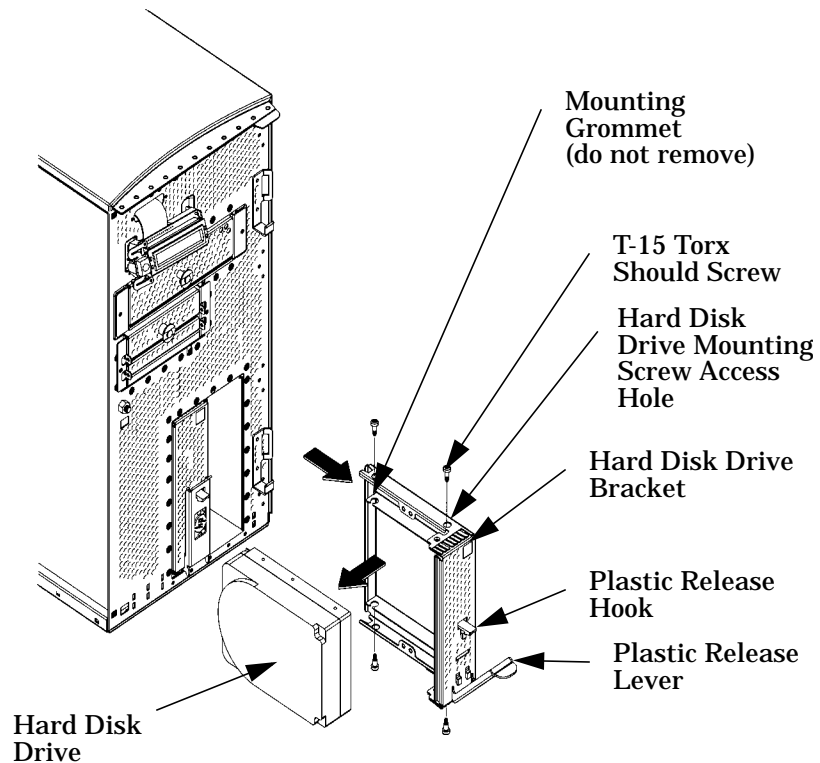

4. Replace the four mounting screws on the hard disk drive bracket to store them for future use. Slide the mounting bracket into its hard drive slot, and push inward on the release lever until the front of the hard drive bracket is flush with the system unit and the release lever snaps closed. See Figure 5-43. The front panel should now be replaced as explained in the section “Closing the System Unit Front Panel” in this chapter.

Figure 5-43 Replacing the Hard Disk Drive Bracket

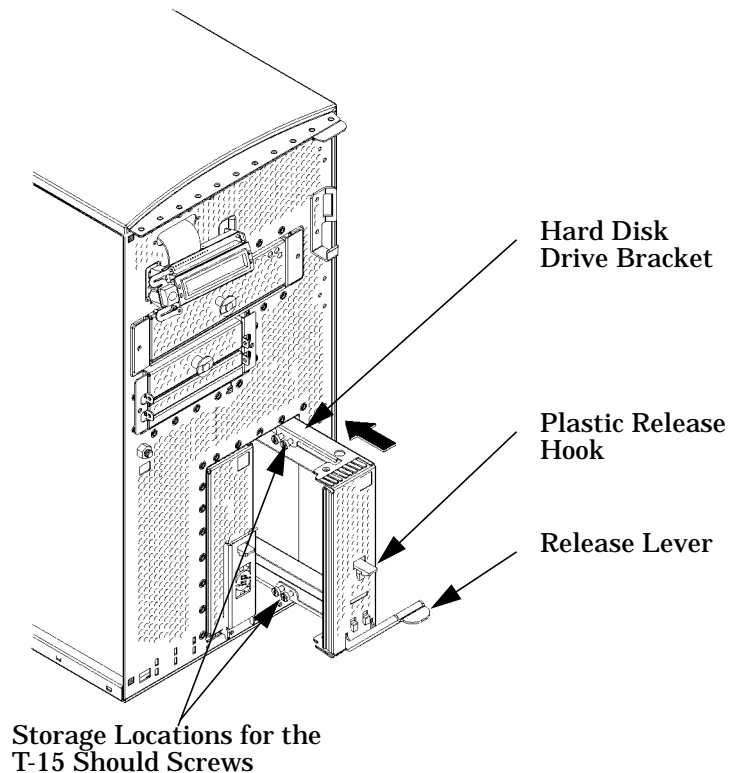

Configuring a Hard Disk Drive as a File System

This section describes how to add a hard disk drive to your system as a file system using SAM and how to remove the hard disk drive from your system. For more information about configuring a hard disk drive, refer to the manual *Managing Systems and Workgroups*.

The procedures in this section require you to log in as `root`. If you cannot log in as `root`, contact your system administrator.

Adding a Hard Disk Drive as a File System Using SAM

Here is the procedure you need to follow to add a hard disk drive as a file system using SAM.

1. Log in as `root`.
2. Move the mouse pointer to the **Application Manager** control for tools and click the left mouse button. Alternatively you can execute `sam` at a terminal window command prompt and skip to step 5.



3. Double click on the **System_Admin** icon in the **Application Manager** window.



4. Double click on the **Sam** icon in the **Application Manager -- System_Admin** window. If you are root, the **System Application Manager (SAM)** will appear on your screen.



5. Double click on the **Disk and File System** icon.



6. Double click on the **Disk Devices** icon.



The following screen message is displayed:

```
Scanning the system's hardware...
```

The **Disk and File Systems** window opens containing a list of drives installed in this system. From the list of devices, choose the hard disk drive you would like to configure as a file system by clicking on the device to highlight it.

7. Click on **Add** in the Actions menu. For this example you will select the item **Not Using the Logical Volume Manager**. However, you can select any appropriate item from the **Actions** menu.

Changing Your Computer Hardware Configuration

Hard Disk Drives

8. Enter the mount directory name (for example, /disk1) in the **Mount Directory** field of the **Add Disk without LVM** window.
9. Click on the **OK** button in the **Add Disk without LVM** window. You will need to wait for a short time before the new file system is created and the hard disk drive is mounted. When the **Add Disk without LVM** window disappears and HFS appears in the Use column of the **Disk and File Systems** window, your task will be complete.

Removing a Hard Disk Drive as a File System Using SAM

Here is the procedure you need to follow to remove a hard disk drive as a file system using SAM.

1. Log in as root.
2. Move the mouse pointer to the **Application Manager** control for tools and click the left mouse button. Alternatively you can execute `sam` at a terminal window command prompt and skip to step 5.



3. Double click on the **System_Admin** icon in the **Application Manager** window.

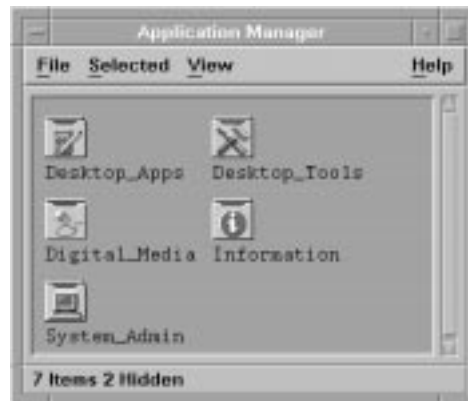

4. Double click on the Sam icon in the **Application Manager -- System_Admin** window. If you are root, the **System Application Manager (SAM)** will appear on your screen.



5. Double click on the **Disk and File System** icon.



6. Double click on the **Disk Devices** icon.



The following screen message is displayed:

```
Scanning the system's hardware...
```

The **Disk and File Systems** window opens containing a list of devices installed in this system. From the list of devices, choose the hard disk drive you would like to remove (unmount) by highlighting that device.

Changing Your Computer Hardware Configuration

Hard Disk Drives

7. Click on **Remove** in the **Actions** menu. In the window that next appears, click on the **Yes** button. This will unmount the file system located on the hard disk drive you are removing from the system unit. You will need to wait for a short time before the new file system is unmounted. The file system is successfully unmounted when you see Unused in the Use column of the **Add Disk without LVM** window.

Memory Cards

This section contains information regarding the installation and removal of memory (DIMM cards). However, before continuing with this section, please take time to read the following list of considerations:

- Use the procedure described in “The Boot Console Interface” chapter to determine the current memory configuration for this computer. This should be done before trying to install additional memory DIMMs in your computer.
- Read over the steps in the section “Installing Additional Memory” before you begin the installation of your DIMM cards.
- Inserts DIMMs in the order shown. Please refer to Figure 5-45.
- Be sure you understand the proper orientation for DIMMs when inserting them into their connectors because the connectors are keyed to prevent you from putting them in backwards. See Figure 5-46.
- Use the “Boot Console Interface” to verify that the computer recognizes the additional DIMMs when you have finished installing them. Note that you can also use SAM and select the **Performance Monitor** icon, then the **System Properties** icon, and in the window that appears, select the tab labeled **Memory**.

Installing Additional Memory

Perform the following steps to add memory (DIMM cards) to your computer.

NOTE

Lay the system on its right side (using the system unit’s front panel as a reference) as shown in Figure 5-44. Note that before laying the system unit on its side you should put it on a cushioned surface to avoid damage to the system unit’s exterior.

1. Open the side panel of the system unit as explained in the section “Opening the Left Side Panel of the System Unit” in this chapter.

Changing Your Computer Hardware Configuration

Memory Cards

2. Prop up the system unit power supply as explained in the section “Propping Up the System Unit Power Supply” in this chapter.

Figure 5-44 Propping Up the Power Supply

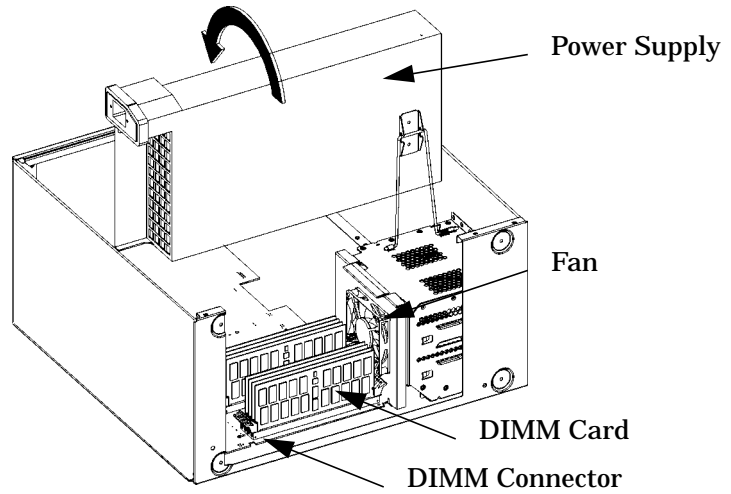

3. Position the memory slots so they face you as shown in Figure 5-45. Note that Figure 5-45 also provides the loading sequence for the DIMM cards. This loading sequence must be maintained when you install the DIMM cards, but the size of the DIMM card put in each slot can vary. For example, you can install a 128Mbyte card before a 256Mbyte card and then follow the installation of the 256Mbyte card with another 128Mbyte card. The B1000 and C3000 computers use only 128 Mbyte and 256 Mbyte DIMM cards.
4. Remove the hard disk drive fan as explained in the section “Removing the Fan from the Hard Disk Drive Area” in this chapter, and load the DIMM cards in the slots using the loading sequence provided in Figure 5-45.

Figure 5-45 Memory Card Slot Numbers and Loading Sequence

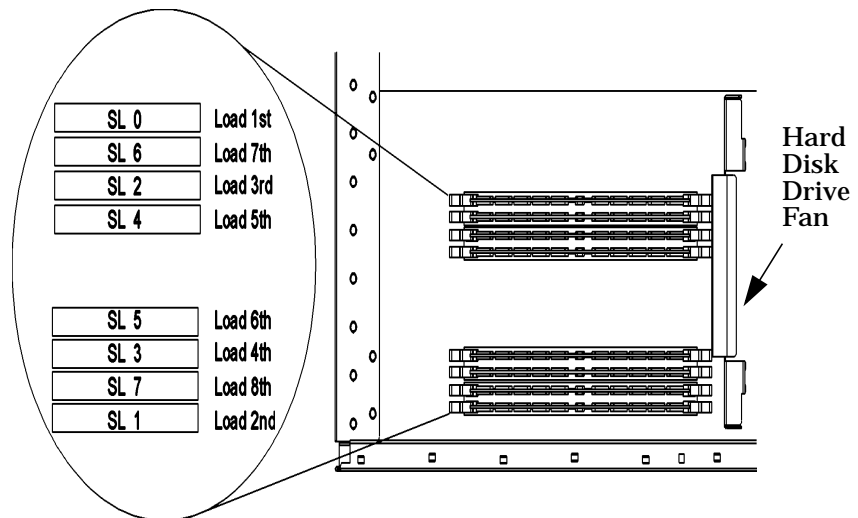

NOTE

When installing memory, you need to orient the notches on the bottom edge of the DIMM card so that they are aligned with the keys on the DIMM connector. See Figure 5-46. The keyed DIMM connectors prevent you from installing the DIMM cards backwards.

Changing Your Computer Hardware Configuration

Memory Cards

5. Press downward on the ejector tabs located on both sides of the DIMM connector. See Figure 5-46. This opens the connector for DIMM card insertion.

Figure 5-46 Installing Memory Cards

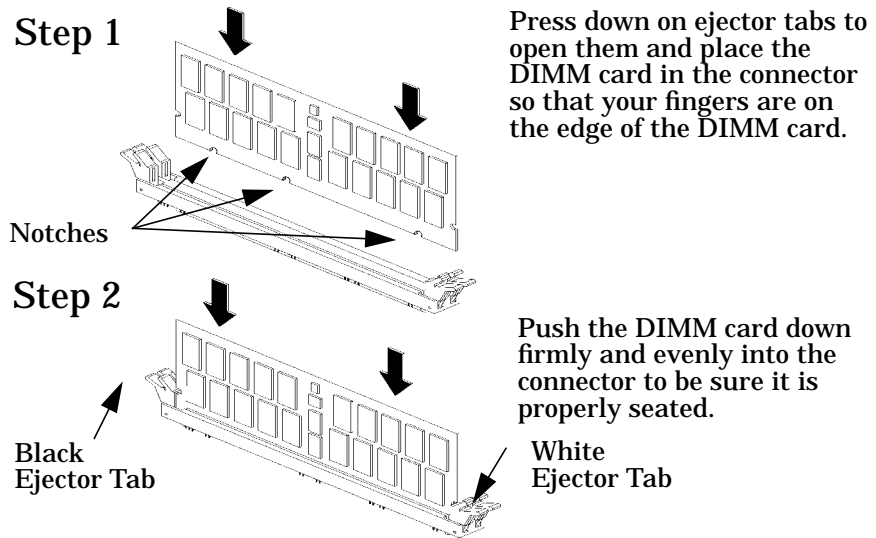

6. Place the DIMM card in the connector, lining it up with the guides. Make sure you align the notches on the bottom edge of the DIMM card with the DIMM connector keys. See Figure 5-46.
7. Press firmly and evenly on the DIMM card to ensure that it seats properly, and replace the hard disk drive fan as explained in the section “Replacing the Hard Disk Drive Fan” in this chapter.
8. Replace the left side panel as explained in the section “Closing the System Unit after Propping Up the Power Supply” in this chapter. Plug the power cord back in to the electrical outlet.
9. Verify that this installation was successful by following the steps in the section “Displaying the Current Memory Configuration” in the chapter “The Boot Console Interface” in this document.

Once you have completed the steps listed above, your DIMM cards are properly loaded.

Removing Memory

Perform the following steps to remove memory (DIMM cards) from your system unit.

NOTE

Lay the system on its right side (using the system unit's front panel as a reference) as shown in Figure 5-47. Note that before laying the system unit on its side you should put it on a cushioned surface to avoid damage to the system unit's exterior.

1. Open the side panel of the system unit as explained in the section “Opening the Left Side Panel of the System Unit” in this chapter.
2. Prop up the system unit power supply as explained in the section “Propping Up the System Unit Power Supply” in this chapter.

Figure 5-47 Propping Up the Power Supply

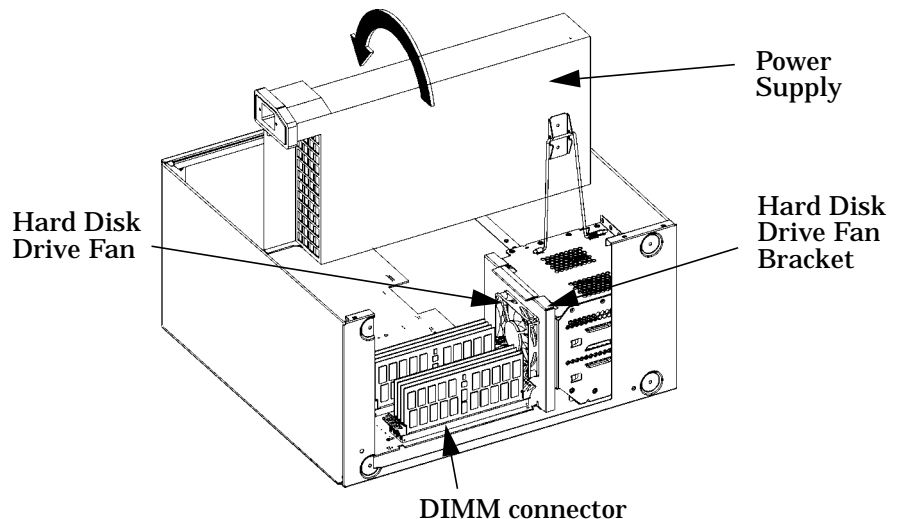

3. Remove the fan from the hard disk drive chassis. See the section “Removing the Fan from the Hard Disk Drive Area” in this chapter.

4. Press downward on the ejector tabs located on both sides of the DIMM connector. See Figure Figure 5-48. This raises the DIMM card for easy extraction.

Figure 5-48 **Removing Memory Cards**

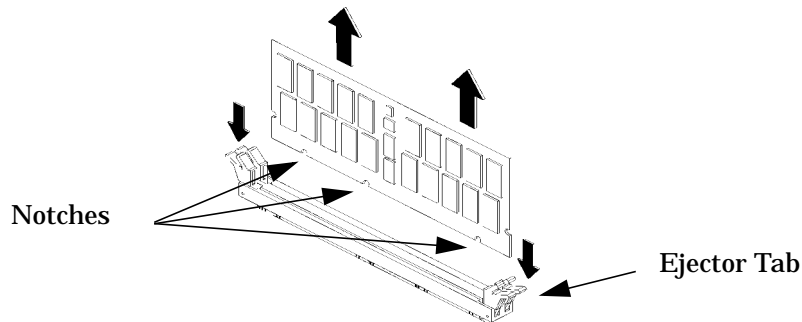

5. Lift up evenly on the outside edges of the DIMM card to remove it. See Figure 5-48.
6. Install the remaining DIMM cards in the correct order. See Figure 5-45.
7. Replace the hard disk drive fan as explained in the section “Replacing the Hard Disk Drive Fan” in this chapter.
8. Replace the left side panel as explained in the section “Closing the System Unit after Propping Up the Power Supply” in this chapter. Plug the power cord back in to the electrical outlet.
9. Verify that this removal was successful by following the steps in Chapter 6 of this book, “The Boot Console Interface.” Note that you can also use SAM and select the **Performance Monitor** icon, then the **System Properties** icon, and in the window that appears, select the tab labeled **Memory**.

Changing Your Monitor Type

Your system ships from the factory preset to use a monitor with a specific resolution and frequency. If you replace your monitor with a different type, you must reconfigure your computer to support it.

There are three ways to configure your computer to support a different monitor type. They are discussed in the subsequent sections.

Setting the Monitor Type at Power On

If you replace your computer monitor with a different type of monitor, and you have not set the computer's graphics parameters by using the Boot Console Interface's monitor command, you can still configure your computer's new monitor type when you reboot the system.

To set the monitor type, you will need to:

1. Press the **Tab** key after your keyboard's Num Lock light comes on during the boot process to initiate the automatic monitor selection process. Your system will query you for a new monitor type. Note that if you have waited more than 15 minutes for a monitor type to appear, go to the section "Troubleshooting Monitor Problems" in this chapter.
2. Select one of the monitor types listed on the screen and press **Enter**. If your monitor is not listed in the section "Monitors" in the chapter "System Overview" in this document, a common monitor type to select is 12.
3. Answer yes, by pressing **Y**, to the system query to confirm your selection. Note that if you do not make a selection, the system cycles through the possible monitor types continuously until you do make your selection. See the section "Displaying and Setting the Monitor Type" in Chapter 6.

Setting the Monitor Type from the Boot Console Interface

To change your computer's graphics parameters before you replace your monitor, go to the section "Displaying and Setting the Monitor Type" in Chapter 6.

Setting the Monitor Type Using SAM

This method for setting the monitor type requires the use of the HP CDE interface. This means that you should have already set your monitor type using one of the methods defined in a previous section, or you have an Instant Ignition system that boots up using the HP CDE interface.

To use the **System Administration Manager** (SAM) to set the monitor type, follow the steps in this procedure:

1. Log in as `root`.
2. Move the mouse pointer to the Application Manager control for tools and click the left mouse button. Alternatively you can execute `sam` at a terminal window command prompt and skip to step 5.



3. Double click on the **System_Admin** icon in the **Application Manager** window.

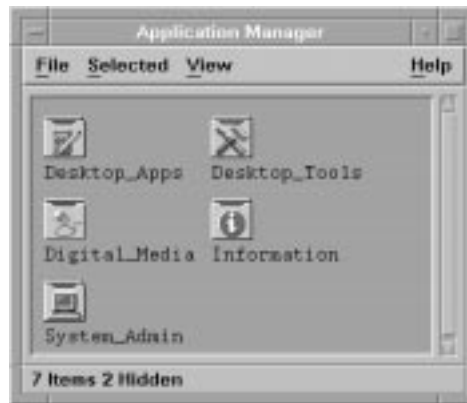

4. Double click on the **Sam** icon in the **Application Manager -- System_Admin** window. If you are **root**, the **System Application Manager (SAM)** will appear on your screen.



5. Double click on the **Display** icon.



6. Double click on the **Monitor Configuration** icon in the **Display** window.



The **Monitor Configuration** window will have a monitor icon(s) in it that is/are associated with the graphics card(s) in your system units I/O card slot(s).

7. Click on the monitor icon in the **Monitor Configuration** window whose monitor type you want to set.

Changing Your Monitor Type

8. Select the action **Modify Monitor Type** from the **Action** menu. You will see a window with a list of monitor type selections in it. Here is an example of a monitor type entry you may see:

Entry	Width	Height	Hz	Font	Description
1	1280	1024	75	10x20	PCI

9. Select an entry from the list in the **Modify Monitor** window. In that same window, select the check box labeled **Make monitor type '*n*' the default** where *n* is the number of the entry you selected. To finish your monitor type selection, select the **Modify Monitor** window's **OK** button. A pop-up window will appear to confirm your monitor type selection. Press the **Yes** button in that pop-up window. This causes the monitor to reset, possibly hiding existing windows. You will then be given 15 seconds after the monitor type changes to configure this setting. Press the **OK** button to configure the setting. This completes the process for setting the monitor type. Note that this change takes effect immediately.
10. Connect your monitor cable to the graphics card you selected, and your screen contents will appear. You are now done selecting your monitor type.

Troubleshooting Monitor Problems

In the event that your console stops displaying to your graphics device, use the following procedure to set the console for displaying to an external terminal.

Here are the steps to follow:

1. Turn system power off.
2. Disconnect the computer keyboard connector from the system rear panel.
3. Connect a serial terminal emulator to the Serial 1 connector (the left serial connector) on the system rear panel.
4. Power on the system. The system will now display the console to the terminal connected to Serial 1 port. Note that you can use a 9-pin to 9-pin serial cable (HP F1044-80002) to connect an HP OminiBook serial port to the workstation.
5. Set the monitor type and path using the Boot Console Interface. For information on doing this see the chapter “The Boot Console Interface” in this document.

6 **The Boot Console Interface**

This chapter describes the different features of the boot console interface and how to use them.

The Boot Console Interface

Here are the topics covered in this chapter:

- Boot Console Interface Features
- Accessing the Boot Console Interface
- Booting Your Computer
- Searching for Bootable Media
- Resetting Your Computer
- Displaying and Setting Paths
- Displaying and Setting the Monitor Type
- Changing the Console to an External Terminal
- Displaying the Current Memory Configuration
- Displaying the Status of the System I/O
- Setting the Auto Boot and Auto Search Flags
- Displaying and Setting the Security Mode
- Displaying and Setting the Fastboot Mode
- Displaying the LAN Station Address
- Displaying System Information

Boot Console Interface Features

There are times when you want to interact directly with the hardware of your computer before it boots the operating system. Your computer provides a menu-driven boot console interface that allows you to perform special tasks, display information, and set certain system parameters, even if the operating system is unavailable.

Here are some of the things you can do:

- Boot your computer
- Search for bootable media
- Reset your computer
- Display and set boot paths
- Display and set your monitor type
- Display memory configuration information
- Display the status of the PCI slots
- Set Auto Boot, Auto Search and Auto Start
- Set Fastboot
- Display LAN information
- Display system information

The boot console menus follow, showing the various tasks you can perform and the available information.

The shortened version of all commands is indicated by the uppercase letters.

Help is available for all the menus and commands by using either **help**, **he** or **?** and the menu or command for which you want help.

The Boot Console Interface

Boot Console Interface Features

Hear are the menus:

```
----- Main Menu -----  
  
Command                Description  
-----  
BObot [PRI|ALT|<path>]    Boot from specified path  
PAtH [PRI|ALT|CON|KEY|[<path>] Display or modify a path  
SEArCh [DIsply|IPL] [<path>] Search for boot devices  
  
COntfiguration [<command>] Access Configuration menu/commands  
INformation [<command>]    Access Information menu/commands  
SERvice [<command>]       Access Service menu/commands  
  
DIsply                 Redisplay the current menu  
HElp [<menu>|<commands>] Display help for menu or command  
RESET                 Restart the system  
  
-----  
Main Menu: Enter command >
```



```
----- Configuration Menu -----  
  
Command                Description  
-----  
  
AUto [B0ot|SEArch] [ON|OFF]    Display or set specified auto flag  
BootID [<proc>] [<boot ID>]    Display or modify processor boot ID  
BootINfo                    Display boot-related information  
BootTimer [0 - 200]           Seconds allowed for boot attempt  
CPUconfig [<proc>] [ON|OFF]    Config/deconfig processor  
DEfault                      Set the system to predefined values  
FastBoot [ON|OFF]            Display or set boot tests execution  
LanConfig                    Display or set LAN Configuration  
MONitor [LIST|<path> <type>]  Change the current monitor type  
PAth [PRI|ALT|CON|KEY] [<path>] Display or modify a path  
SEArch [DISplay|IPL] [<path>] Search for boot devices  
SECure [ON|OFF]              Set/show security mode  
Time [c:y:m:d:h:m:s]         Read or set real time clock in GMT  
PreviousPower [ON|OFF]       Set previous power state  
  
B0ot [<menu>|<command>]       Boot from specified path  
DISplay                       Redisplay the current menu  
HElp [<menu>|<command>]       Display help for menu or command  
RESET                          Restart the system  
MAin                          Return to Main Menu  
-----  
Configuration Menu: Enter command >
```

The Boot Console Interface

Boot Console Interface Features

----- Information Menu -----

Command	Description
ALL	Display all system information
BootInfo	Display boot-related information
CAche	Display cache information
ChipRevisions	Display revisions of VLSI and firmware
COprocessor	Display coprocessor information
FwrVersion	Display firmware version
IO	Display I/O interface information
LanAddress	Display built-in system LAN address
MEmory	Display memory information
PRocessor	Display processor information
WARnings	Display selftest warning messages
BOot [PRI ALT <path>]	Boot from specified path
DIspay	Redisplay the current menu
HElp [<menu> <command>]	Display help for menu or command
RESET	Restart the system
MAin	Return to Main Menu

Information Menu: Enter command >

----- Service Menu -----

Command -----	Description -----
ChassisCodes [<proc> ON OFF]	Display/enable/disable chassis codes
CLEARPIM	Clear (zero) the contents of PIM
EepromRead [<addr>] {<len>}	Read EEPROM locations
MemRead <addr> [<len>] [<type>]	Read memory locations
PCIDelay [<value>]	Display or set PCI delay value
PDT [CLEAR]	Display or clear the Page Deallocation Table
PIM [<proc> [HPMC LPMC TOC]]	Display PIM information
ScRoll [ON OFF]	Display or change scrolling ability
BOot [PRI ALT <path>]	Boot from specified path
DIisplay	Redisplay the current menu
HElp [<menu> <command>]	Display help for menu or command
RESET	Restart the system
MAin	Return to Main Menu

Service Menu: Enter command >	

Accessing the Boot Console Interface

If the system unit has crashed or power was turned off for some reason, press the power switch and proceed to step 3. Otherwise, to access the boot console interface, follow these steps:

NOTE

This procedure should be done by a system administrator or superuser with root log in permission.

1. Close any files and applications on your computer.
2. Press the power switch on the front panel of the system unit.

NOTE

There is no need to log in as `root` and execute the `shutdown -q` command to shut down the HP-UX operating system on your computer before powering it off. When you turn off the power switch, your computer automatically shuts down the operating system before terminating the power.

Make sure you do not unplug the system's power cord or otherwise interrupt power to the system unit at this time.

When the operating system has been properly shut down, the following message will appear:

```
Shutdown complete
```

3. Power on your computer after your system has completely shut down. If `auto boot` is turned off, the boot sequence automatically stops at the boot console Main Menu.

If `auto boot` is turned on, you will see the following message:

```
Processor is starting auto boot process. To  
discontinue, press any key within 10 seconds.
```

If auto boot and auto search are both turned on, you will see the following message:

```
Processor is booting from first available de-  
vice. To discontinue, press any key within 10  
seconds.
```

NOTE

If you are using a power-saving monitor, you will have less than 10 seconds from the time this message appears to press a key.

4. Press a key. You will then see the message:

```
Boot terminated
```

The Main Menu of the boot console appears.

Booting Your Computer

You usually start your computer by turning it on and waiting for HP-UX to boot automatically. However, you may not always want the usual sequence to occur.

For example, you may want to start your computer from an operating system that is stored on a device that is different from your usual boot device. If your normal operating system kernel or the disk on which it resides becomes damaged or unusable, you may wish to boot from a different disk or perhaps another type of device, such as a CD drive.

Here are some possible booting scenarios you may encounter:

- If you know which device you want to boot from, and you know that it contains a bootable operating system, follow the directions in “Accessing the Boot Console Interface” earlier in this chapter, and then type the following at the prompt:

```
Main Menu: Enter command > boot device
```

where *device* is the hardware path to the device, specified in Mnemonic Style Notation. For example, if you wish to boot an operating system that is stored on a DDS-format tape drive that is located at the hardware path `scsi.1.0`, you would type the following command at the prompt and press **Enter**:

```
Main Menu: Enter command > boot scsi.1.0
```

- If you do not know which device you want to boot from, then type the following at the prompt and press **Enter**:

```
Main Menu: Enter command > search
```

A message similar to the following will be displayed:

Path Number	Device Path	Device Type
P0	IDE	TEAC CD-532E-B
P1	FWSCSI.6.0	SEAGATE ST39102LC

At the prompt, you might type the following and press **Enter**:

```
Main Menu: Enter command > boot P1
```

Note that the operating system on the specified device (P1) is used to boot your computer (also see the section “Searching for Bootable Media”).

- If you wish to interact with the Initial System Loader (ISL) before booting your computer, follow the directions in “Accessing the Boot Console Interface” earlier in this chapter, and then type the following at the prompt:

```
Main Menu: Enter command > boot device
```

The following prompt will appear:

```
Interact with ISL (Y,N,Q)>
```

Answering yes (Y) causes the ISL to be loaded from the specified device. After a short time, the following prompt appears on your screen:

```
ISL>
```

ISL is the program that actually controls the loading of the operating system. By interacting with ISL, you can choose to load an alternate version of the HP-UX operating system. If you do not want to interact with ISL, you must enter no (N).

The Boot Console Interface

Booting Your Computer

For example, if the usual kernel (`/stand/vmunix`) on your root disk (`fwscsi.6.0`) has become corrupted, and you wish to boot your computer from the backup kernel (`/stand/vmunix.prev`), type the following at the `ISL>` prompt and press Enter:

```
ISL> hpux /stand/vmunix.prev
```

- If you do not know which media in your file systems have bootable operating systems, you can find them with the `search ipl` command. See the subsequent section “Searching for Bootable Media.”

Searching for Bootable Media

To list devices that contain bootable media, follow the directions in “Accessing the Boot Console Interface” earlier in this chapter, and then type the following at the prompt and press **Enter**:

```
Main Menu: Enter command> search ipl
```

The search command searches all buses. The search may turn up more devices than there are lines on your display. If you are using a text terminal, you may control the progress of the search from your terminal's keyboard by using these keystrokes:

Ctrl S Temporarily suspends the search.

Ctrl Q Continues the search.

Any Other Key Stops the search.

These flow-control keystrokes do not work with a bitmapped display, but such a display can show more than forty lines of text, so you are unlikely to need them.

To search for devices of just one type that actually contain bootable media, follow the directions in “Accessing the Boot Console Interface” earlier in this chapter, and then type the following at the prompt and press **Enter**:

```
Main Menu: Enter command> search ipl device_type
```

where *device_type* is one of the following:

`fwscsi` Is the built-in Ultra2 Wide LVD SCSI bus.

`scsi` Is the built-in Fast Narrow Single-Ended SCSI bus.

`lan` Is all connections to the built-in LAN.

`pcin` Is an optional SCSI interface in slot number *n*.

`ide` Is a built-in IDE bus.

Resetting Your Computer

To reset your computer to its predefined values, follow the directions in “Accessing the Boot Console Interface” earlier in this chapter, and then type the following at the prompt and press **Enter**:

```
Main Menu: Enter command> co
```

When the Configuration Menu appears, type the following at the prompt and press **Enter**:

```
Configuration Menu: Enter command> default
```

When the Configuration Menu appears again, type the following at the prompt and press **Enter**:

```
Configuration Menu: Enter command> reset
```

Displaying and Setting Paths

A path is the hardware address of a device that is attached to the I/O system of your computer. The path command sets the system paths shown in Table 6-1.

The path command sets and displays the hardware address of a specified device attached to the I/O bus of your computer.

Table 6-1 **System Paths**

Path Type	Device
primary or pri	Your computer's default boot device (usually the root disk)
alternate or alt	Your computer's alternate boot device (usually a DDS-format tape device)
console or con	Your computer's primary display device
keyboard or key	Your computer's primary input ASCII device

To display the current settings for the system paths, type the following at the prompt and press **Enter**:

```
Main Menu: Enter command> path
```

The paths are displayed in Mnemonic Style Notation, as shown in Table 6-2.

Table 6-2 **Mnemonic Style Notation for Boot Paths**

I/O Type	Specification Format
Built-in LVD SCSI	<i>fwscsi.scsi_address.logical_unit_number</i>
Built-in NSE SCSI	<i>scsi.scsi_address.logical_unit_number</i>
Built-in LAN	<i>lan.server_address.init_timeout.io_timeout</i>
Built-in IDE	<i>ide</i>

The Boot Console Interface

Displaying and Setting Paths

To display the current setting for a particular system path, follow the directions in “Accessing the Boot Console Interface” earlier in this chapter, and then type the following at the prompt and press **Enter**:

```
Main Menu: Enter command> path path_type
```

where *path_type* is one of the path types listed in Table 6-1.

For example, to get the path to the primary boot device, follow the directions in “Accessing the Boot Console Interface” earlier in this chapter, and then type the following at the prompt and press **Enter**:

```
Main Menu: Enter command> path primary
```

To set a system path to a new value, follow the directions in “Accessing the Boot Console Interface” earlier in this chapter, and then type the following at the prompt and press **Enter**:

```
Main Menu: Enter command> path path_type path
```

where *path_type* is one of the path types listed in Table 6-1 and *path* is the specification of the path in Mnemonic Style Notation (as described in Table 6-2). For example, to set the primary boot path to a SCSI disk with ID of 6.0, follow the directions in “Accessing the Boot Console Interface” earlier in this chapter, and then type the following at the prompt and press **Enter**:

```
Main Menu: Enter command> path pri scsi.6.0
```

Displaying and Setting the Monitor Type

Your system ships from the factory preset to use a monitor with a specific resolution and frequency. If you replace your computer's monitor with a different type of monitor, you may have to reconfigure your computer to support the new monitor.

The Monitor Command

The `monitor` command lets you change your computer's graphics configuration. This command is available in the Configuration Menu of the boot console interface.

NOTE

The `monitor` command lets you change your computer's graphics configuration before you replace your monitor. For information about changing the configuration after you replace your monitor, refer to "Changing Your Monitor Type" in Chapter 5.

To display the current graphics and console information, type the following set of commands and press **Enter** at the prompt:

```
Main Menu: Enter command> configuration
```

```
Configuration Menu: Enter command> monitor
```

The Boot Console Interface

Displaying and Setting the Monitor Type

The correct usage for setting the graphics configuration is:

```
monitor graphics_path type
```

where valid `graphics_path` parameters are:

```
graphics(1)  Graphics adapter installed in slot 1
graphics(2)  Graphics adapter installed in slot 2 (primary slot)
graphics(3)  Graphics adapter installed in slot 3
graphics(4)  Graphics adapter installed in slot 4 (secondary slot)
graphics(5)  Graphics adapter installed in slot 5
graphics(6)  Graphics adapter installed in slot 6
```

and `type` is the numerical monitor type. See “Setting the Monitor Type” in a subsequent section for a list of types. For example, an HP VISUALIZE-EG graphics card (A4977A) installed in option slot 2 would be `graphics(2)`. Note that you can have `graphics(1)` through `graphics(6)` for your `graphics_path`; however, there are two preferred I/O slots available for graphics cards in your computer. Those slots are slots 2 and 4. Slot 2 is the primary graphics card slot, and slot 4 is the secondary graphics card slot.

Displaying the Current Monitor Configuration

To display the current monitor configuration for your system from the Configuration Menu of the boot console interface, follow the directions in “Accessing the Boot Console Interface” earlier in this chapter. Once you are in the Boot Console Interface Main Menu, type the following command and press **Enter**:

```
Main Menu: Enter command> configuration
```

This places you in the Configuration Menu. From here, type the following command at the prompt and press **Enter**:

```
Configuration Menu: Enter command> monitor
```

The message on your display is a list of the current graphics adapters and their monitor types configured for your computer.

MONITOR INFORMATION

Path	Slot	Head	HPA	Resolution	Freq	Type	Class
GRAPHICS(2)	2	1	fffa000000	1280x1024	75Hz	1	PCI

```
Configuration Menu: Enter command>
```

In this example, only the graphics adapter (located in slot 2) GRAPHICS(2) is configured. The monitor type for GRAPHICS(2) is set to type 1, which is a 1280×1024 monitor that uses a frequency of 75 Hz.

Setting the Monitor Type

You can set the monitor type for a graphics adapter by typing the following at the prompt and pressing Enter:

```
Configuration Menu: Enter command> monitor graphics(n) tt
```

where *n* is the number of the graphics adapter and *tt* is the monitor type. To display a list of supported monitors that are used by your graphics card, type the following command at the prompt and press Enter:

```
Configuration Menu: Enter command> monitor list
```

A list of valid monitor types similar to the following is displayed:

MONITOR INFORMATION

Path	Slot	Head	Type	Size	Freq	Class
GRAPHICS(2)	2	1	1	1280x1024	75Hz	PCI
GRAPHICS(2)	2	1	2	1280x1024	75Hz	PCI, Double buffered
GRAPHICS(2)	2	1	3	1280x1024	75Hz	PCI, Greyscale
GRAPHICS(2)	2	1	4	1280x1024	75Hz	PCI, Double buffered, Greyscale
GRAPHICS(2)	2	1	5	1280x768	75Hz	PCI
GRAPHICS(2)	2	1	6	800x600	75Hz	PCI
GRAPHICS(2)	2	1	7	640x480	75Hz	PCI
GRAPHICS(2)	2	1	8	1600x1200	75Hz	PCI
GRAPHICS(2)	2	1	9	1600x1200	75Hz	PCI, Greyscale
GRAPHICS(2)	2	1	10	1200x1600	75Hz	PCI
GRAPHICS(2)	2	1	11	1200x1600	75Hz	PCI, Greyscale
GRAPHICS(2)	2	1	12	1280x1024	72Hz	
GRAPHICS(2)	2	1	13	1280x1024	72Hz	Double buffered
GRAPHICS(2)	2	1	14	640x480	60Hz	
GRAPHICS(2)	2	1	15	-----	user defined	-----

```
Configuration Menu: Enter command>
```

To set the monitor type for GRAPHICS(2) to monitor type 1, type the following at the command prompt and press Enter:

```
Configuration Menu: Enter command> monitor graphics(2) 1
```

This will take effect on the next reboot or reset of the system.

MONITOR INFORMATION

Path	Slot	Head	HPA	Resolution	Freq	Type	Class
GRAPHICS(2)	2	1	fffa000000	1280x1024	75Hz	1	PCI

```
Configuration Menu: Enter command>
```

The boot console displays a message that tells you that your new monitor selection will take effect the next time you reboot your system. The boot console also displays the new monitor information.

Trying to change the monitor type to a number not listed for that graphics device fails and gives you the following warning message:

```
Value of monitor type n out of range (n - nn)
```

Trying to change the monitor type on an empty slot fails and gives you the following warning message:

```
No such graphics card.
```

Setting the Monitor Type with SAM

The System Administration Manager (SAM) allows you to change the monitor type after the HP-UX 10.20 or 11.0 operating system release have been installed and running on your system unit. This section provides a brief explanation on how to set the monitor type using SAM. Note that you will need to be logged in as `root` to run SAM.

Here are the steps for setting your monitor type with SAM:

1. Log in as `root`.
2. Move the mouse pointer to the **Application Manager** control for

The Boot Console Interface

Displaying and Setting the Monitor Type

tools and click the left mouse button. Alternatively you can execute `sam` at a terminal window command prompt and skip to step 5.



3. Double click on the **System_Admin** icon in the **Application Manager** window.

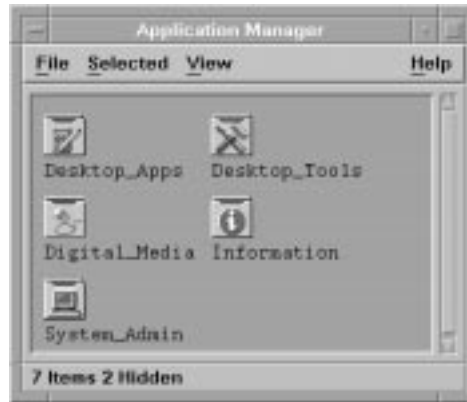

4. Double click on the Sam icon in the **Application Manager -- System_Admin** window. If you are root, the **System Application Manager (SAM)** will appear on your screen.



5. Double click on the **Display** icon.



6. Double click on the **Monitor Configuration** icon in the **Display** window.



The **Monitor Configuration** window will have a monitor icon(s) in it that is/are associated with the graphics card(s) in your system units I/O card slot(s).

7. Click on the monitor icon in the **Monitor Configuration** window whose monitor type you want to set.
8. Select the action **Modify Monitor Type** from the **Actions** menu. You will see a window with a list of monitor type selections in it. Here is an example of a monitor type entry you may see:

Entry	Width	Height	Hz	Font	Description
1	1280	1024	75	10x20	PCI

9. Select an entry from the list in the **Modify Monitor** window. In that same window, select the check box labeled **Make monitor type 'n' the default** where **n** is the number of the entry you selected. To finish your monitor type selection, select the **Modify Monitor** window's **OK** button. A pop-up window will appear to confirm your monitor type selection. Press the **Yes** button in that pop-up window. This causes the monitor to reset, possibly hiding existing windows. You will then be given 15 seconds after the monitor type changes to configure this setting. Press the **OK** button to configure the setting. This completes the process for setting the monitor type. Note that this change takes effect immediately.
10. Connect your monitor cable to the graphics card you selected, and your screen contents will appear. You are now done selecting your monitor type.

Setting the Monitor Type at Power On

If you replace your computer's monitor with a different monitor type, you need to let the computer's firmware know you made this change. To do this, reboot the system and use either the automatic monitor selection process or the boot console interface's `monitor` command. The monitor command is described in the section "Setting the Monitor Type" in this chapter. The automatic monitor selection process is described in this section.

Once you have rebooted the system by turning it off, wait for a short time for the hard disk drive's disk to stop spinning. Next, turn the computer on and watch for the Num Lock light to come on.

NOTE

It takes a short amount of time (approximately 40 seconds) after powering on the computer before the Num Lock light comes on.

Wait two seconds after the Num Lock light comes on, which is near the end of the boot sequence, then press **Tab** to initiate the automatic monitor selection process. If your screen remains blank after two minutes of waiting for something to be displayed, see the section "Troubleshooting Monitor Problems" in this chapter. Otherwise, if you see information similar to the following displayed on your screen and it is the correct monitor type, press the **Enter** key to select it.

```
Path      Slot  Head  Type      Size      Freq  Class
-----  -
GRAPHICS(2)  2    1     n   nnnnxnnnn  nnHz   PCI
```

Press [Return] to select this monitor type (type *n* of *n* types).

Note that if you do not select this monitor type, the system cycles through all of the available monitor types one at a time until you find one that meets your needs.

Once you have made your monitor type selection, the system queries you to confirm your selection. Press **Y** to save this monitor type.

If you press any key other than **Y**, the following message is displayed:

```
Monitor type not saved.
```

At this point, the new monitor type is active, but not saved. Because you did not save the monitor type, the next time you reboot the system the original monitor type will be used.

Next, the following message is displayed:

```
To select a new Graphics Monitor Type press the <TAB> key now, otherwise EXIT by  
entering any other key (or will time out in 15 seconds)...
```

To restart the monitor selection process, press **Tab**.

Troubleshooting Monitor Problems

In the event that your console stops displaying to your graphics device, use the following procedure to set the console for displaying to an external terminal.

Here are the steps to follow:

1. Turn system power off.
2. Disconnect the computer keyboard connector from the system rear panel.
3. Connect a serial terminal emulator to the Serial 1 connector (the left serial connector) on the system rear panel. Configure the terminal for: 9600 baud, No Stop Bits, No Parity, 8 Bits.
4. Power on the system. The system will now display the console to the terminal connected to Serial 1 port. Note that you can use a 9-pin to 9-pin serial cable (HP F1044-80002) to connect an HP OmniBook serial port to the workstation.
5. Set the monitor type and path using the Boot Console Interface. For information on doing this see the section “Setting the Monitor Type with SAM.”

Changing the Console to an External Terminal

In the event that your console stops displaying to your graphics device, use the following procedure to display the console to an external serial terminal so that you can configure the graphics console:

1. Turn the system's power off.
2. Disconnect the USB keyboard connector from the system rear panel.
3. Connect a serial terminal to the "Serial 1" connector on the system back panel. Configure the terminal for: 9600 baud, No Stop Bits, No Parity, 8 Bits.
4. Power on the system.

The system will now display the console to the terminal connected to Serial 1 port.

Displaying the Current Memory Configuration

The following sample screen output uses the `memory` command to show a memory configuration table with properly-installed and configured memory.

To display the current memory configuration for your system, from the Information Menu of the boot console interface, follow the directions in “Accessing the Boot Console Interface” earlier in this chapter. Once you are in the Boot Console Interface Main Menu, type the following at the prompt and press **Enter**:

```
Main Menu: Enter command>information
```

This places you in the Information Menu. From here, type the following at the prompt and press **Enter**:

```
Information Menu: Enter command> memory
```

The screen displays status and configuration information for the memory DIMMs installed in your computer. See the section “Memory Information Sample.”

The Boot Console Interface
Displaying the Current Memory Configuration

Memory Information Sample

The following example shows the memory information when memory modules are properly installed and configured:

MEMORY INFORMATION

MEMORY STATUS TABLE

Slot	Size	Status
0	256MB	Active
1	256MB	Active
2	128MB	Active

TOTAL MEMORY = 640MB

MEMORY FAULT TABLE

Slot	Size	Status
------	------	--------

Active, Installed Memory	:	640MB of SDRAM
Deallocated Pages	:	0 Pages
Available Memory	:	640MB
Good Memory Required by OS	:	0 (Not Initialized)
Memory		
HVERSION	SVERSION	
0x0860	0x0900	

Displaying the Status of the System I/O

The `io` command lets you identify all built-in I/O devices and optional I/O devices installed in the option slots. It is available in the Information Menu.

To use the IO command from the Information Menu of the boot console, type the following command at the prompt and press **Enter**:

```
Information Menu: Enter command> io
```

Information about the built-in and optional I/O devices is displayed.

```
I/O MODULE INFORMATION
```

Path	Decimal	Type	Location	HVER	SVER	IODC Vers	IODC Dep
----	-----	----	-----	----	----	----	---
LAN	10/0/12/0	Ethernet	built-in	0060	a200	0x02	0x00
AUDIO	10/0/13/0	Audio	built-in				
IDE	10/0/14/0	IDE	built-in	0060	a300	0x00	0x00
SUPERIO MISC	10/0/14/0	Bridge Device	built-in				
FLOPPY	10/0/14/1/0	Floppy Disk	built-in				
SERIAL_1	10/0/14/1/1	RS232 port	built-in	0060	8c00	0x01	0x00
SERIAL_2	10/0/14/1/2	RS232 port	built-in	0060	8c00	0x01	0x00
PARALLEL	10/0/14/1/3	Parallel port	built-in				
USB	10/0/14/2	USB	built-in	0060	a900	0x95	0x00
SCSI	10/0/15/0	SCSI	built-in	0060	a300	0x00	0x00
FWSCSI	10/0/15/1	SCSI	built-in	0060	a300	0x00	0x00
GRAPHICS(2)	10/6/2/0	Display	slot 2	0070	8500	0x01	0x00

```
Main Menu: Enter command >
```

Setting the Auto Boot and Auto Search Flags

The `auto boot` and `auto search` flags are variables stored in your computer's nonvolatile memory. (Nonvolatile memory retains its contents even after power is turned off.) If you reset these flags to new values, the change takes effect the next time you reboot the computer.

The `auto boot` flag boots the operating system whenever your computer is turned on.

If `auto boot` is set to on, your computer automatically attempts to boot the operating system when turned on. If `auto boot` is set to off, your computer enters the boot administration mode of the boot console user interface.

The state of the `auto search` flag determines how your computer seeks a boot device during auto boot. If `auto search` is set to on, your computer will search for other boot devices if the primary boot device is not available. If `auto search` is off, your computer will default to the boot administration mode if it can't see the primary boot device.

To examine the state of the `auto boot` and `auto search` flags, type the following at the prompt and press **Enter**:

```
Configuration Menu: Enter command> auto
```

To change the state of the `auto boot` or `auto search` flags, type the following at the prompt and press **Enter**:

```
Configuration Menu: Enter command> auto boot state
```

or

```
Configuration Menu: Enter command> auto search state
```

where *state* is on or off.

The `auto search` command searches for devices in the following order:

- Primary boot path (can be set by the user)
- Alternate boot path (can be set by the user)
- Low-voltage differential SCSI (built-in)
- PCI 1 through PCI 6 (plug-in interface cards)
- Narrow single-ended SCSI (built-in)
- LAN (built-in)

Displaying and Setting the Security Mode

The `secure` flag is a variable stored in non-volatile memory. (Non-volatile memory retains its contents even after power is turned off.) If you reset this flag to a new value, the change takes effect the next time you reboot the computer.

When the `secure` flag is set to on, auto boot and auto search are enabled and cannot be stopped. The system boots from the default boot paths regardless of user intervention.

Note that the `secure` command must be executed from within the Boot Console Interface. To get into the Boot Console Interface, follow the procedure in the section “Accessing the Boot Console Interface” in this chapter. Once the Main Menu is present, you can type the following command at the prompt and press **Enter**:

```
Main Menu: Enter command > configuration
```

From the Configuration Menu, you can execute the `secure` command and perform the subsequent tasks in this section.

To display the current setting for the `secure` flag, type the following command at the prompt and press **Enter**:

```
Configuration Menu: Enter command > secure
```

To set the `secure` flag on, type the following command at the prompt and press **Enter**:

```
Configuration Menu: Enter command > secure on
```

To set the `secure` flag off, you need to disconnect the boot disk to interrupt the boot-up sequence and force the prompt to the Boot Console Interface. Next, type the following command at the prompt and press **Enter**:

```
Configuration Menu: Enter command > secure off
```

Displaying and Setting the Fastboot Mode

When `fastboot` is enabled (set to on), your computer does a quick check of the memory and skips I/O interface testing during its power-on self tests. This enables your computer to complete its boot process quicker. The default factory setting is for `fastboot` to be enabled (set to on). Note that `fastboot` can be set using the Boot Console Interface's Configuration Menu.

When `fastboot` is disabled (set to off), more extensive memory testing and I/O interface testing is performed during the self tests, causing the boot process to take longer.

If you are experiencing difficulty in booting your computer, set `fastboot` to off and reboot the system. More extensive testing may reveal the error condition.

To display the status of `fastboot`, type the following at the prompt and press **Enter**:

```
Configuration Menu: Enter command> fastboot
```

To disable `fastboot`, type the following at the prompt and press **Enter**:

```
Configuration Menu: Enter command> fastboot off
```

To enable `fastboot`, type the following at the prompt and press **Enter**:

```
Configuration Menu: Enter command> fastboot on
```

Displaying the LAN Station Address

It is sometimes necessary to supply the LAN station address of your computer to other users. For example, if your computer is to become a member of a cluster, the cluster administrator needs to know your LAN station address in order to add your computer to the cluster. Note that your LAN station address can be determined using the Boot Console Interface's Information Menu.

A LAN station address for your computer is the label that uniquely identifies the LAN connection for your computer at the link level (the hardware level).

To display your workstation's LAN station addresses, type the following at the prompt and press **Enter**:

```
Information Menu: Enter command> lanaddress
```

The LAN station address is displayed as a twelve-digit number in hexadecimal notation, similar to the following:

```
LAN Station Address:          001083-000429
```

The address is for the system's built-in LAN.

Displaying System Information

The `all` command allows you to display the system's processor revision and speed, cache size, memory size, flag settings, and the boot and console paths. To display system information for the Information Menu, type the following at the prompt and press **Enter**:

```
Information Menu: Enter command> all
```

This information is paged to allow you to view it as necessary unless the service `ScRoll` command has been used to disable scrolling.

The Boot Console Interface
Displaying System Information

Solving Problems

To help speed up your service request, have your system's model number and serial number available. Your service representative will always ask for these numbers.

The instructions in this chapter assume you are using the HP-UX 10.20 or 11.0 operating system with the HP CDE graphical interface. When using HP CDE, you will have to use command line options in a terminal window to perform tests.

Here are the topics covered in this chapter:

- Common Problems and Solutions
- Dealing with a Boot Failure
- Memory Failures
- LCD Information
- Running System Verification Tests.

NOTE

This chapter requires you to log in as `root`. If you cannot log in as `root`, contact your system administrator.

Common Problems and Solutions

The tables in this section lists common problems you may encounter with your computer. The tables also tell you what to do to help solve the problems.

Table 7-1 **Problems Powering Up the System**

Problem	Solution
The LCD screen does not light up.	Make sure all AC power cables are connected securely to the system. Make sure the power cord is plugged into a working AC outlet. Make sure the power is turned ON.
The LCD screen lights up , but the screen is blank	Make sure the LCD control cable is properly connected inside the system unit.
LCD messages	See “LCD Information” later in this chapter.
If problems persist, contact your system administrator or call your designated service representative.	

Table 7-2 **Problems Loading and Booting the Operating System**

Problem	Solution
The LCD screen is lit, and text appears on the screen, but more than two minutes have passed with no sign of system activity.	Make sure that all SCSI devices are set to the proper SCSI ID. (See Appendix C for default SCSI ID settings.) Check that all SCSI devices are correctly cabled. Check that the SCSI bus is correctly terminated. (See Chapter 4 for information on SCSI cabling and termination.)
The system stops or hangs while booting.	Follow the instructions in “Dealing with a Boot Failure” later in this chapter. If the LCD displays a DIMM error, follow the instructions in “Memory Failures” later in this chapter.
If problems persist, contact your system administrator or call your designated service representative.	

Table 7-3 **Problems with the 802.3 Network**

Problem	Solution
Cannot reach other systems on the network. Applications that rely on the network will not run.	Check the network connector on the back of the system unit. Make sure the network cable or transceiver is fastened securely to the connector. The link LED should be lit solid, and the activity LED should be solid or flashing.
If problems persist, contact your system administrator or call your designated service representative.	

Table 7-4 Problems Using a Hard Disk Drive

Problem	Solution
<p>The disk drive is not accessible or does not respond.</p>	<p>Make sure that all SCSI devices are set to the proper SCSI ID. (See Chapter 4 for default SCSI ID settings.)</p> <p>Check that all SCSI devices are correctly cabled. Check that the SCSI bus is correctly terminated. (See Chapter 4 for information on SCSI cabling and termination.)</p> <p>Open the disk tray again and close it.</p> <p>Follow the instructions in “Dealing with a Boot Failure” later in this chapter.</p> <p>If the disk drive is external to the system unit, make sure that its power is turned ON.</p>
<p>If problems persist, contact your system administrator or call your designated service representative.</p>	

Table 7-5 Problems Using the CD Drive

Problem	Solution
<p>The CD drive does not respond to commands (for example, mount or swinstall).</p>	<p>Re-enter the commands and make sure you have typed them correctly.</p> <p>See the section “Running System Verification Tests” later in this chapter to verify that the CD drive is functioning properly.</p> <p>Make sure power and data cables are connected.</p>
<p>If problems persist, contact your system administrator or call your designated service representative.</p>	

Table 7-6 **Problems Using the Floppy Disk Drive**

Problem	Solution
The floppy drive does not respond to commands.	<p>Re-enter the commands and make sure you have typed them correctly.</p> <p>Make sure you specified the device file</p> <p style="text-align: center;"><code>/dev/floppy/c0t1d0</code></p> <p>for commands that require a device file name.</p> <p>Make sure the write-protect tab is set to write if you are trying to copy data to a floppy diskette.</p> <p>Follow the instructions in the section “Running System Verification Tests” later in this chapter to verify that the floppy disk drive is functioning properly.</p> <p>Make sure cables (power, data, etc.) are connected.</p>
If problems persist, contact your system administrator or call your designated service representative.	

Dealing with a Boot Failure

If your usual boot device (typically a disk) is not responding as it should, you must try to boot from the disk (or another boot device) by selecting it manually. Note that you must be superuser (`root`) to perform the steps in this section.

To boot a device manually, follow these steps:

NOTE

A common cause of boot failures is forgetting to connect your Ultra2 Wide Low-Voltage Differential SCSI terminator and your Fast Narrow Single-Ended SCSI terminator to their connectors on the back of your system unit. Note that these terminators were shipped with your system unit.

-
1. Follow the directions in “Accessing the Boot Console Interface,” in Chapter 6 of this document.

NOTE

Your computer automatically shuts down the operating system before it terminates the power.

-
2. At the Main Menu prompt, type the following and press **Enter**:

```
Main Menu: Enter command > search ipl
```

This causes your computer to search exhaustively for bootable media.

3. Boot from one of the listed devices by typing the following at the prompt and press **Enter**:

```
Main Menu: Enter command > boot device
```

where *device* is the hardware path to the device, specified in mnemonic style notation, such as `FWSCSI.5.0`.

4. Answer “N” to the question, `INTERACT WITH IPL (Y,N,Q)?`

5. If your computer still fails to boot, there is either something wrong with the file system or with the hardware. If you suspect a file system failure, see the manual *Using HP-UX* for help on dealing with file system failures. If you think that something is wrong with the hardware, continue reading this chapter for more troubleshooting information.

Memory Failures

A memory failure will show up in the LCD on your system unit's front panel as a DIMM error. Your system's Boot Console Interface will never appear.

A possible solution to the memory failure problem is to perform the procedure in the section "Installing Additional Memory" in the chapter "Changing Your Computer Hardware Configuration." If the problem persists, contact your system administrator or call your designated service representative.

LCD Information

Your computer uses an LCD panel to display firmware/OS progress codes. The codes, referred to as chassis codes, consist of one of the mnemonics listed below, followed by a 4-digit hexadecimal number identifying the code module being executed. The mnemonics and their meanings are:

FLT	A hardware error has been detected
TST	Hardware being tested
INI	Hardware being initialized
SHU	System being shutdown
WRN	A non-optimal or unusual operating condition exists
RUN	Computer is running operating system

In general, the LCD display has the following format:

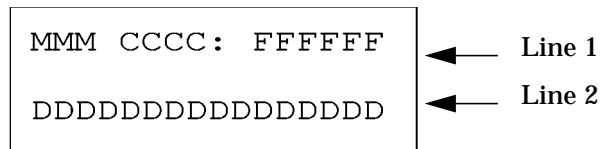

MMM	Three character mnemonic
CCCC	Four digit hexadecimal code
FFFFFFF	Six character field replaceable unit description
DDDDDDDDDDDDDDDDDD	Description of the chassis code

If the system encounters a `FLT` code while the system is booting, the `FLT` code is interpreted and a message is displayed. For example, you may have information similar to the following in the LCD:

<code>FLT</code>	Three character chassis code
<code>30FC</code>	Four digit hexadecimal code
<code>SYS BD</code>	Six character field replaceable unit description
<code>bad sys bd id</code>	Description of the chassis code

LCD Fan Failures and Warnings

This section provides the failure and warning messages you will see in your computer's LCD if there is a problem with a fan in your system unit.

Table 7-7 lists the fan numbers and their names. The fan numbers will appear in the description of the chassis code in your computer's LCD.

Table 7-7

Fan Numbers and Their Names

Fan Number	Name of the Fan
2	Lower System Fan (tower standing up)
3	Upper System Fan (tower standing up)
4	I/O Fan
5	CPU Fan
6	Hard Disk Drive Fan

Here is an example of a failure message for the I/O fan:

```
WRN D010 SYS BD
fan failed: # 4
```

Here is an example of a warning message for the CPU fan:

```
WRN D020 SYS BD
fan warning: # 5
```

Figure 7-1 will help you locate the problem fan within your system unit.

Figure 7-1

Fan Locations

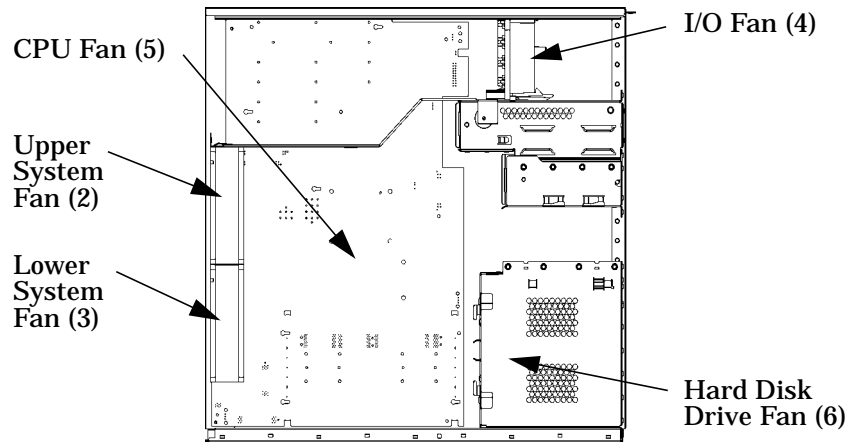

If you should receive a failure or warning in you LCD, you should record the information on a piece of paper and call in the problem to your local HP Support Representative. The representative will want the LCD failure or warning message you record for determining the course of action to take regarding possible repairs.

Troubleshooting Monitor Problems

In the event that your console stops displaying to your graphics device, use the following procedure to set the console for displaying to an external terminal.

Here are the steps to follow:

1. Turn system power off.
2. Disconnect the computer keyboard connector from the system rear panel.
3. Connect a serial terminal to the Serial 1 connector (the left serial connector) on the system rear panel. Configure the terminal for: 9600 baud, No Stop Bits, No Parity, 8 Bits.
4. Power on the system. The system will now display the console to the terminal connected to Serial 1 port. Note that you can use a 9-pin to 9-pin serial cable (HP F1044-80002) to connect an HP OminiBook serial port to the workstation.
5. Set the monitor type and path using the Boot Console Interface. For information on doing this see the chapter “The Boot Console Interface” in this document.

Running System Verification Tests

HP-UX uses a diagnostics product called MESA that includes the Support Tools Manager (STM), which allows system operation verification. To use STM, you need to be on an HP-UX 10.20 or 11.0 operating system and HP-UX Diagnostic/IPR Media on your computer.

There are three interfaces that allow you access to the Support Tools Manager: a command line interface (accessed through the `cstm` command), a menu-driven interface (accessed through the `mstm` command), and the graphical user interface (accessed through the `xstm` command).

For more information on these user interfaces, see the online manual pages by entering one of the following command at the command line prompt and pressing **Enter**:

```
man cstm
```

```
man mstm
```

```
man xstm
```

Safety and Regulatory Statements

Here are the topics covered in this appendix:

- Declaration of Conformity
- Emissions Regulations
- Third Party Emissions Regulations Compliance
- Special Regulatory and Safety Information
- Warnings and Cautions

Declaration of Conformity

Declaration of Conformity according to ISO/IEC Guide 22 and EN 45014	
Manufacturer:	Hewlett-Packard Company 3404 East Harmony Road Fort Collins, CO 80528 USA
Declares that the:	
Product Name:	HP VISUALIZE Workstation
Model Numbers:	B Class and C Class
conforms to the following specifications:	
Safety	IEC 950:1991+A1+A2+A3 +A4 +A11/ EN 60950:1992+A1+A2+A3+A4 +A11 IEC 60825-1:1993/EN60825-1:1994+A11 USA 21CFR Subpart J - for FC Laser module China GB4943-1995 Russia GOST R 50377-92
EMC	CISPR 11: 1990 / EN 55011: 1991 Class B CISPR 22: 1993 / EN 55022: 1994 Class B EN 50082-1:1992 IEC 1000-3-2: 1995 / EN 61000-3-2: 1995 IEC 1000-3-3: 1995 / EN 61000-3-3: 1995 IEC 1000-4-2: 1995 / EN 61000-4-2: 1995 - 4kV CD, 8 kV AD IEC 1000-4-3: 1995 / EN 61000-4-3: 1995 - 3 v/m IEC 1000-4-4: 1995 / EN 61000-4-4: 1995 - 2 kV Signal, 4 kV Power Lines US FCC Part 15, Class B Japan VCCI Class B Australia/New Zealand AS/NZS 2046.1/2:1992, AS/NZS 3548:1995, and AS/NZS 4251.1:1994 China GB9254-1988 Taiwan CNS13438 Class A Russia GOST R 29216-94
and is certified by:	
	UL Listed to UL1950, 2nd edition, File E146385 cUL Listed to CSA 22.2 No.950-M93 T V Certified to EN60950 2nd edition with A1+A2+A3+A4+A11 HP Fort Collins CCQD HQE
supplementary information:	
The product herewith complies with the requirements of the following Directives and carries the CE marking accordingly: - the EMC directive 89/336/EEC and 92/31/EEC and 93/68/EEC - the Low Voltage Directive 73/23/EEC and 93/68/EEC	
This product was tested in a typical Hewlett Packard workstation configuration.	
Ruth Lutes, Site Quality Manager Fort Collins, CO, USA	
For Compliance Information ONLY, contact:	
European Contact:	Your local Hewlett-Packard Sales and Service Office or Hewlett-Packard GmbH, Department HQ-TRE Standards Europe, Herrenberger Straße 130, D-71034 Böblingen (FAX: +49-7031-14-3143)
Americas Contact:	Hewlett-Packard, Fort Collins Site Quality Manager, mail stop 46, 3404 E. Harmony Rd., Ft. Collins, CO 80528, USA

Emissions Regulations

The HP VISUALIZE B Class and C Class computer is FCC Class B compliant. Note that if a video out cable is connected to your Video Out card, then your computer is no longer FCC Class B compliant as stated in the subsequent section “Special Video Configuration Statement.”

For FCC B Applications:

This equipment has been tested and found to comply with the limits for a Class B digital device, pursuant to part 15 of the FCC rules and the Canadian Department of Communications. These limits are designed to provide reasonable protection against harmful interference in a residential installation. This equipment generates, uses, and can radiate radio frequency energy and, if not installed and used in accordance with the instructions, may cause harmful interference to radio communications. However, there is no guarantee that interference will not occur in a particular installation. If this equipment does cause harmful interference to radio or television reception (determined by turning the equipment off and on), you should try to correct the interference by one or more of the following measures:

- Reorient or relocate the receiving antenna.
- Increase the separation between the equipment and the receiver.
- Connect the equipment into an outlet on a circuit different from that to which the receiver is connected.
- Ask the dealer or an experienced radio/television technician for help.

Hewlett-Packard's system certification tests were conducted with HP-supported peripheral devices and HP-shielded cables, such as those you receive with your computer. Changes or modifications not expressly approved by Hewlett-Packard could void the user's authority to operate the equipment.

Operation of this device is subject to the following conditions:

- This device may not cause harmful interference.
- This device must accept interference received, including interference that may cause undesired operation.
- Cables used with this device must be properly shielded to comply with the requirements of the FCC.

EMI Class A RRL (Korea)

사용시 안내문 (A급 기기)

이 기기는 업무용으로 전자파장애감정을 받은 기기이오니, 만약 잘못 구입하셨을 때에는 구입한 곳에서 비업무용으로 교환하시기 바랍니다.

VCCI Class B ITE (Japan)

この装置は、情報処理装置等電波障害自主規制協議会（VCCI）の基準に基づくクラスB情報技術装置です。この装置は、家庭環境で使用することを目的としていますが、この装置がラジオやテレビジョン受信機に近接して使用されると、受信障害を引き起こすことがあります。

取り扱い説明書に従って正しい取り扱いをして下さい。

EMI Class A (Taiwan)

警告使用者：
這是甲類的資訊產品，在居住的環境中使用時，可能會造成射頻干擾，在這種情況下，使用者會被要求採取某些適當的對策。

Special Video Configuration Statement

When a Video Out card has a cable connected to its video out connector, the HP VISUALIZE B Class and C Class computer no longer meets FCC Class B regulations. The computer now becomes FCC Class A compliant. This statement applies only to those applications which include a cable connected to the video out connector on a Video Out card. No modification to the regulatory statements is necessary for applications which include cables connected to other connectors on the card but not to the Video Out connector.

Third Party Emissions Regulations Compliance

Any third-party I/O device installed in HP system(s) must be in accordance with the requirements set forth in the preceding Emissions Regulations statements. In the event that a third-party noncompliant I/O device is installed, the customer assumes all responsibility and liability arising therefrom.

Special Regulatory and Safety Information

This section covers regulatory and safety information for acoustics, lasers, and LEDs.

Acoustics

Table A-1 Regulation On Noise Declaration For Machines -3. GSGV

Lpa <70dB operator position normal operation per ISO 7779	Lpa<70dB am Arbeitsplatz normaler Betrieb nach DIN 45635 T.19
--	--

Laser Safety Statement (U.S.A. Only)

The CD-ROM mass-storage system is certified as a Class 1 laser product under the U.S. Department of Health and Human Services (DHHS) Radiation Performance Standard according to the Radiation Control for Health and Safety Act of 1968.

This means that the mass-storage system does not produce hazardous laser radiation. Because laser light emitted inside the mass-storage system is completely confined within protective housings and external covers, the laser beam cannot escape from the machine during any phase of user operation.

LEDs

The LEDs on this product are classified as “Class 1 LED PRODUCT” in accordance with EN 60825-1.

Warnings and Cautions

WARNING:

Removing device cover may expose sharp edges in equipment chassis. To avoid injury, use care when installing customer add-on devices.

WARNUNG:

Das Entfernen der Geräteabdeckung legt die scharfen Kanten im Inneren des Gerätes frei. Um Verletzungen zu vermeiden, seien Sie vorsichtig beim Einbau von zusätzlichen Bauteilen, die vom Kunden selber eingebaut werden können.

AVERTISSEMENT:

Des bords tranchants du châssis de l'équipement peuvent être exposés quand le cache de l'unité n'est pas en place. Pour éviter des blessures, faire très attention lors de l'installation de modules supplémentaires par le client.

WARNING:

Disconnect power plug from wall outlet or source power before moving or removing the device, or installing add-on components.

WARNUNG:

Entfernen Sie die Stromzuführung von der Steckdose oder der Stromquelle bevor Sie das Gerät bewegen, abbauen, oder zusätzliche Bauteile installieren.

AVERTISSEMENT:

Débrancher la fiche de la prise de courant ou de la source d'alimentation électrique avant de déplacer ou de retirer l'unité, ou avant d'installer des modules supplémentaires.

Safety and Regulatory Statements
Warnings and Cautions

Glossary

A

Absolute pathname The full pathname of a file, including all the directories leading to it, starting with the root directory (“/”) and ending with the filename itself *See also file, filename, pathname.*

Access permissions Settings that allow (or prevents) a user or group of users to read, write, or execute files *See also file access permissions.*

Active window The window that is receiving input from the keyboard at the present time. If there is no active window, anything you type is lost. Only one window can be the active window.

ANSI The American National Standards Institute, a non-profit organization, made up of various expert committees, that publishes standards for use by national industries. ANSI has adopted the IEEE standards for local area networks.

Argument A part of a command line or line of source code that identifies the file, directory, or other data to be used; a parameter.

Attachment unit interface (AUD) A transceiver cable that conforms to IEEE 802.3 specifications.

B

Backup v. To make a copy of one or more files on a tape or disk that can be stored separately from the original files.

Backup n. A spare copy of one or more files on a tape or disk that can be used to restore data into its original location.

Bitmap Generally speaking, an array of data bits that define a graphical image. Strictly speaking, a bitmap is a pixmap whose depth is one bit, capable of representing two-color (black-and-white) images.

Boot Short for “bootstrap,” from the phrase “pulling oneself up by one’s bootstraps.” Indicates the beginning of a process from the lowest possible level. A boot service is provided by a short program, stored in the boot ROM (read-only memory) of your workstation, that loads the operating system (or any complex program) into main memory. Partner workstations provide bootstrap service to

diskless workstations. See also boot ROM.

Boot console interface The interactive firmware that enables you to interact with the hardware of your workstation before the workstation boots the operating system. The boot console interface allows you to perform special tasks, display information, and set certain system parameters.

Boot ROM A read-only memory that is incorporated into a workstation for the purpose of loading and starting the operating system, and modifying the configuration or changing the booting behavior.

Bootstrap service *See boot.*

Byte A fundamental character-code unit, usually consisting of 8 bits.

C

CD-RAM Compact Disk Random-Access Memory. *See also CD-RAM disk, CD-RAM drive.*

CD-RAM disk CD-RAM (CD-RW) disks are identical to the audio compact disks (CDs) used to record stereo music, except computer data

is read from and written to these disks. CD-RAM disks are 120 mm (4.7 inches) in diameter, use one data surface, and have a capacity of about 650 MB. The data surface contains pits and flat spots arranged in a continuous spiral track, which is read at a constant linear speed.

CD-RAM drive A random-access, read/write, mass-storage device that uses removable CD-RAM disks. The drive contains a semiconductor laser for reading and writing data optically and an embedded controller.

CD-ROM Compact Disk Read-Only Memory. *See also CD-ROM disk, CD-ROM drive.*

CD-ROM disk CD-ROM disks are identical to the audio compact disks (CDs) used to record stereo music, except that they store computer data. CD-ROM disks are 120 mm (4.7 inches) in diameter, use one data surface, and have a capacity of about 650 MB. The data surface contains pits and flat spots arranged in a continuous spiral track, which is read at a constant linear speed.

CD-ROM drive A random-access, read-only, mass-storage device that

uses removable CD-ROM disks. The drive contains a semiconductor laser for reading data optically and an embedded controller.

Central Processing Unit (CPU)

The part of a workstation that interprets and executes instructions; the “brain.”

Child directory *See subdirectory.*

Click To press and immediately release a mouse button. The term comes from the fact that pressing and releasing most mouse buttons makes a clicking sound. Compare drag and drop.

Cluster A group of workstations connected via a Local Area Network (LAN). One workstation, the cluster server, acts as a file-system server for the cluster clients. *See also cluster client, cluster node, cluster server.*

Cluster client. A cluster node that does not have a local HP-UX file system. Its file system resides on the cluster server. *See also cluster, cluster node, cluster server.*

Cluster node A member of a

group of workstations connected via a Local Area Network (LAN). One workstation, the cluster server, acts as a file server to the other machines in the cluster. *See also cluster, cluster client, cluster server.*

Cluster server A workstation that provides file access, login access, file transfer, printing, and other services across a network to a defined cluster of systems (cluster nodes) connected via a LAN. *See also cluster, cluster client, cluster node, host.*

Cold install. A process that requires the booting of an install kernel from an install server over a network or from a CD-ROM and answering some configuration questions.

Command. An instruction that you enter into the system at a prompt, to execute a program or perform a task. *See also shell command.*

Command argument

Information you provide on a command line to describe the object (often a file or directory) to be operated on by the command.

Command interpreter A program that reads lines of text from standard input (typed at the keyboard or read from a file) and interprets them as requests to execute commands or programs. An HP-UX command interpreter is called a shell. *See also shell.*

Command option Information you provide on a command line to indicate any special action you want the command to take, or mode in which to operate. *See also default.*

Configuration The arrangement of a workstation or network as defined by the nature, number, and chief characteristics of its functional units. More specifically, the term “configuration” may refer to a hardware configuration or a software configuration.

Console. The tty (terminal) the system was booted from. The console is associated with the monitor where all system messages are displayed. The system administrator sends messages to other system users from this tty.

Control key sequence. A keystroke combination used as a shorthand way of specifying

commands. To enter a control key sequence, hold down the “Ctrl” key while pressing another key.

CPU *See Central Processing Unit.*

Current directory *See current working directory.*

Current session The work and processes that have been created since you logged into the system (and before you log out again).

See also session.

Current working directory The directory from which a relative-pathname search begins, as well as the directory in which you are currently working. It is also called the “working directory” or “current directory.”

Cursor The small, usually blinking, box or underline displayed in whatever screen or window is active at any particular time. The cursor marks your current typing position on the screen and indicates which program (HP CDE terminal window or shell) will receive your typed commands.

D

Daisy-chaining A method of connecting devices in which the signal passes from one device to the next in serial fashion along a bus.

DDS tape drive A device that stores data on Digital Data Storage (DDS) cassettes.

Default Most commands give you a choice of one or more options. If you don't specify an option, the command automatically assigns one. This automatic option is called the "default." *See also command option.*

Dialog box A special type of HP CDE screen that contains controls and settings, and with which the user can carry on an interactive "dialog" in the process of setting whatever parameters the dialog box requests. To display an example of a dialog box, click the Style Manager button on the Workspace Manager's front panel, then click on Color.

DIMM *See Dual In-line Memory Module.*

Dual In-line Memory Module A memory board whose connectors

on each side of the board are connected to different chips. This allows for a wider data path as more modules can be accessed at the same time.

Directory A special type of "container" object that contains information about the objects beneath it in the HP-UX organizational structure. Basically, it is a file that stores names and links to files and other directories *See also file.*

Disk A thin, round plate with a magnetic or optical surface coating on which data is stored by magnetic or optical means. *See also floppy diskette, hard disk, CD-ROM disk.*

Disked workstation A workstation that has its own hard disk drive.

Diskette *See floppy diskette.*

Double click To press and release a mouse button twice in rapid succession. The amount of time that discriminates between a double click and two single clicks is usually user-configurable. Double clicking usually invokes a different, but related, function than single clicking.

Drag To move the mouse (and hence the pointer on the screen) while holding down one or more of its buttons. This process specifies two separate locations on the screen for those operations that require two: the location when the mouse button is pressed, and the location when it is released. This is used, for example, to initiate a file-copy by pressing the mouse button on the file to be copied, dragging the file's icon to the destination window, and releasing the mouse button there. Another common using of dragging is to specify the upper-left and lower-right corners of a new window or similar rectangle *See also drop.*

Drive *See CD-ROM drive, DDS tape drive, floppy drive, hard disk drive*

Drop To release the mouse button after having moved the mouse with its button held down, in order to position an icon or other object that has been "dragged" to a new position *See also drag.*

E

EEPROM. Electronically erasable read-only memory. Usually bytes or words can be erased and

reprogrammed individually during system operations. The EEPROM is used for storing configuration information that will be "remembered" after a reboot and AC power loss.

Environment The conditions in which your commands or programs are executed. These conditions include your workstation characteristics, home directory, and default search paths *See also environment variables.*

Environment variables The set of defined shell variables (some of which are PATH, TERM, SHELL, EXINIT, and HOME) that define the conditions in which, or values with which, your commands are executed. These conditions and values include your workstation characteristics, home directory, and default search paths *See also environment.*

Ethernet The LAN developed jointly by Digital Equipment Corporation, Intel, and Xerox Corporation, upon which the IEEE 802.3 network is based.

F

File The basic named unit of data stored on disk *See also directory, filename.*

File access permissions The access rights given to a particular file or directory. Every file and directory has a set of access permissions, a code that determines whether a process can perform a requested operation on the file (such as opening the file or writing to it) *See also access permissions.*

File manager The HP CDE application that allows you to manage your files and directories, and to set viewing preferences.

File name The name given to a particular file *See also absolute path name, file, path name.*

File server A workstation whose primary task is to control the storage and retrieval of data from hard disks. Any number of other workstations can be linked to the file server via a LAN in order to use the file server to access data.

File system The hierarchically organized set of files and directories on a hard disk.

Firmware The control software that is embedded in ROM and is always resident regardless of the status of the operating system. It handles the booting of the system, initialization of I/O, and starts the loading of the operating system.

Floppy diskette A thin, flexible, disk-shaped sheet of plastic that magnetically stores data on its coated surfaces. Floppies are contained within stiff plastic “envelopes” to protect them from dust, fingerprints, and abrasion. The floppy drive uses heads (similar to heads in tape recorders) to read and write data on concentric disk tracks.

Floppy drive A device that stores data on a floppy diskette.

H

Hard disk A type of disk that is rigid—often aluminum—as opposed to a thin plastic diskette, which is flexible.

Hard disk drive A device that stores data on a hard disk. The hard disk can be a permanent part of the drive and thus be unremovable, or it can be removable. If it is removable, it is contained in a protective cover that

is opened by the drive when access is needed.

Help manager The HP CDE application that provides online help.

\$HOME The environment variable that contains the name of a user's home directory. This is the directory in which you are placed upon logging in. Typically, this is /home/login, where login is your username. *See also home directory.*

Home directory A shorthand way of referring to a frequently used directory, almost always the login directory.

Host A computer that offers one or more services; may be local or remote (accessible via a network) *See also cluster server.*

Host name *See internet protocol address.*

HP CDE *See HP Common Desktop Environment.*

HP Common Desktop Environment A user interface that draws a graphical layer over the complexities of the other layers of the system (the hardware,

operating system, and X Window system), enabling you to control your workstation by directly manipulating graphical objects instead of by typing commands at a command-line prompt.

HP-UX. This is Hewlett-Packard's version of the UNIX® operating system.

HP-UX cluster *See cluster node, cluster server.*

I

Icon A small, graphic representation of an object. Objects can be "iconized" (turned into icons) to clear a cluttered workspace. Icons can be restored to their original appearance when needed. Whatever processes are executing in an object continue to execute when the object is iconized.

Iconify *See iconize.*

Iconize To turn a window or shell into an icon *See also icon.*

Initial System Loader (ISL)

The program that actually controls the loading of the operating system.

Input device Any of several pieces of hardware equipment used to give information to a system. Examples include the keyboard and the mouse *See also output device.*

Input window The window that displays a program's prompt and any commands typed but not yet executed.

Instant ignition. When the user's computer is turned on and it automatically boots up and is ready for use. Instant Ignition is the result of the computer's operating system being preloaded at the factory.

Install server. This is a networked computer from which file sets and operating systems can be installed.

Internet protocol address (IP address) A string of characters, in the format nnn.nnn.nnn.nnn, that uniquely identifies a workstation in a network. The nnn in the format specifier above is a one- to three-digit decimal integer between 0 and 255, inclusive, in which leading zeroes are optional. The internet protocol address is also referred to as the "IP address."

Invisible file name A filename in which the first character is a period (.). Invisible filenames are not displayed by the listing commands such as ls and ll without additional options, such as -a.

IP address *See internet protocol address.*

ISL *See Initial System Loader.*

K-L

Kernel The part of the operating system that is an executable piece of code responsible for managing the computer's resources. The kernel controls the rest of the operating system.

LAN *See local area network.*

LAN station address *See local area network station address.*

Link n. A special object that contains the name of another object. When you specify a link as a pathname or part of a pathname, the system substitutes the pathname that the link contains.

Link, v. To establish a relationship between two objects such that one of the objects contains only the

information required to associate it with the other, “real,” object.

Local area network (LAN) A data communications system that allows a number of independent devices to communicate with each other. The systems and clusters that share data, hardware, and software resources via Networking Services software.

Local area network system address The label that uniquely identifies the local area network (LAN) connection for your workstation at the hardware level. This 48-bit number is preassigned by HP on their computers and it must never be changed.

Log in v. To initially sign on to the system so that you may begin to use it. This creates your first user process. See also *username*.

Login n. A session. Or, a string of characters that uniquely identifies a user of the system. *See also session, user account, and username.*

Login directory The directory in which you are placed when you log in, usually your home directory. *See also home directory.*

Login manager The program that controls the initial startup of HP CDE and accepts the user’s username and password

Login script The shell program that runs at each login, and sets the login environment for your system.

M

Menu bar An area at the top or bottom of a window that contain the titles of the pull-down or pop-up menus for that application.

Minimize button In HP CDE, a push-button on the window frame that turns a screen into an icon. *See also icon, iconize.*

Monitor type. A monitor path name (*graphics(1)* through *graphics(6)*) that is associated with a particular resolution and refresh frequency at which you want your monitor to operate. The monitor type is selected using the Boot Console Interface. See Chapter 6.

Mouse pointer. *See pointer.*

N

Name A character string associated with a file, directory, or link. A name can include various alphanumeric characters, but never a slash (/) or null character *See also pathname.*

Network Two or more workstations sharing information *See also cluster, workstation.*

Network controller A printed circuit board that passes bit streams between the network and the main memory of the workstation. Coupled with the network transceiver, the controller also handles signal processing, encoding, and network media access.

Node A computer that is on a network. Each node in the network can use the data, programs, and devices of other network nodes, assuming permissions are set up properly. Each node contains main memory and has its own disk or shares one with another node
See also disked workstation, diskless workstation, workstation.

Node name A unique identifying

name given to a workstation in a cluster *See also cluster, node.*

Nonvolatile memory System memory that retains its contents even after workstation power is turned off.

O

Object Any file, directory, or link in the network. See also directory, file, link, pathname.

Operating system The program that supervises the execution of other programs on your workstation. For example, the entire HP-UX system, including the kernel and all HP-UX commands *See also kernel.*

Option *See command option.*

Output device Any of several pieces of hardware used for receiving messages from the computer and storing them, or making them perceptible by humans. Disks and tapes, computer monitors, printers, plotters are examples of output devices *See also input device.*

Output window The window that displays a process response to your command.

P

Parent directory A directory that contains other directories, each of which is then called a subdirectory *See also subdirectory.*

Password The secret word you enter next to the password prompt at login time to permit only authorized access. Keep your password secret and change it occasionally in order to protect your account from unauthorized use *See also user account.*

Path The hardware address of a device that is attached to the I/O system of your workstation.

Path name A slash-separated series of zero or more directory names followed by a filename, that together describe the path within the file system from some starting point to a destination object. Pathnames (other than the degenerate empty case) begin with the name of the starting point, and include every directory name between the starting point and the destination object. A pathname ends with the name of the destination object *See also name, object.*

Permissions A set of rights (read, write, execute) associated with an object in the file system. Determines who may use the object and how.

PID Process Identifier. Also referred to as a process ID *See also process ID.*

PIM. Processor Internal Memory. The pim command is a command used by the Boot Console Interface for determining specific system faults. *See also processor internal memory.*

Pointer Sometimes called the “mouse pointer,” the pointer’s location on the display corresponds to the mouse’s location. The pointer’s shape often depends on the object its hot-spot covers (this is used as a visual feedback mechanism from a program to the user). In the HP CDE Workspace, the default pointer is an X; on a window frame, it is either a simple arrow, or an arrow with one or more straight lines touching it (to indicate any of the eight window-resizing regions).

Process A computing environment in which you may execute programs; a program currently running in the system.

Process ID A unique identification number assigned to all processes by the operating system. Also referred to as a PID

See also PID.

Processor internal memory. A storage area in a processor's internal memory (for example, EEPROM) that is set at the time of a high-priority machine check (HPMC), low-priority machine check, soft boot or TOC, and is composed of the architected state save error parameters, and hardware version-dependent regions.

Program. A unit of executable code, in source-code or binary form. Most HP-UX commands and routines consist of programs.

Prompt A message or symbol displayed by the system to let you know that it is ready for your input.

Push button A graphic control that simulates a real-life push button. Use the pointer and mouse to push the button and start an action or set a state.

R-S

RAM Random-access memory.

ROM Read-only memory.

root *See superuser.*

Scroll bar A vertical or horizontal bar located on the side or bottom of a window that allows the user to view information that does not fit within the window.

SCSI *See Small Computer System Interface.*

SCSI ID. The address of a peripheral device connected to a SCSI bus.

Server. A program that controls all access to input and output devices.

Session The time between when you log in and when you log out. Also called a “work session” or a “login session.” *See also current session.*

Shell A command-line interpreter program used to invoke programs. Some examples of HP-UX shells are the Bourne, Korn, Key, and C shells. Sometimes referred to as a “command interpreter.” *See also command interpreter.*

Shell command An instruction you give the system to execute a utility program or shell script

See also shell script, utility program.

Shell script A file that contains commands that the system can interpret and run in a shell.

Shutdown The process of taking the system from multi-user state to system administration state.

Slider One of the components of a scroll bar. The slider is the object that is dragged along the scroll area to cause the window’s contents to move, exposing previously hidden content.

Small Computer System Interface (SCSI) An IEEE standard for interfacing a computer to multiple, disparate high-speed peripherals such as a disk drive, a CD-ROM drive, or a scanner, etc., singly or in

combination *See also Ultra2 Wide Low-Voltage Differential SCSI, Ultra Narrow Single-Ended SCSI.*

SPA. Soft Physical Address. *See also soft physical address.*

Soft physical address (SPA).

This is a location in system memory associated with the DIMM cards.

Standalone A workstation that is not part of a cluster *See also cluster.*

Style manager The HP CDE application that provides the ability to customize various user-interface aspects of your system, including colors, fonts, keyboard and mouse attributes, session start-up and termination behavior, and access to other workstations.

Subdirectory A directory that is located in, or anywhere on a path below, another directory. The directory above the subdirectory is called the “parent directory.” A subdirectory is also referred to as a “child directory” *See also parent directory.*

Superuser A user with permission to enter any directory and make changes to files and programs that typical users are not allowed to change. To “become superuser” or “become root” means to let the system know that you are now assuming the role of system administrator. You can do this either by logging into the system as user root, or by typing su (switch user) at a command-line prompt. You must know the root password to become root.

System administrator The person responsible for system and network installation, updating, maintenance, and security at your site.

System call Invocation of a kernel process by a user program.

System name *See internet protocol address.*

T-U

Terminal window A terminal window is a type of HP CDE window that emulates a complete display terminal. Terminal windows are typically used to fool window-dumb programs into believing they are running in their

favorite terminal. When not running programs or executing operating system commands, terminal windows display the command-line prompt *See also HP Common Desktop Environment.*

Title bar The rectangular area, between the top of the window and the window frame, that contains the title of the window object.

TOC. *See transfer of control.*

Transceiver. A device that transmits and receives signals.

Transfer of control. Saves the state of the processor in Processor Internal Memory (PIM) and pending I/O operations are not disturbed.

Ultra Narrow Single-Ended SCSI An 8-bit-wide SCSI bus with standard receivers and drivers that runs at 20 Mbytes/second, which allows a cable length of up to 3 meters and a transfer rate of up to 20MB per second *See also Ultra2 Wide Low-Voltage Differential SCSI, Small Computer System Interface.*

Ultra2 Wide Low-Voltage Differential SCSI A 16-bit-wide bus with low-power receivers and drivers, which allows a cable length of up to 12 meters and a data transfer rate of up to 80 MB per second *See also Ultra Narrow Single-Ended SCSI, Small Computer System Interface.*

User account. The system administrator defines a user account for every person authorized to use the system. Each user account contains the name the computer uses to identify the person (user ID), and the person's password. User accounts also contain project and organization names, to help the system determine who can use the system and what resources each person or organization is authorized use *See also user ID, password.*

User ID The name the computer uses to identify you. Your system administrator assigns you a user ID. Enter your user ID during the login procedure when the system displays the login prompt *See also user account.*

Username The name that the system recognizes as uniquely yours. Also known as your "login

name." The username is also the name that identifies you to the mail system and other software requiring secure entry.

Utility *See utility program.*

Utility program A program provided with the operating system to perform a frequently required task, such as printing a file or displaying the contents of a directory *See also command, shell command.*

W

Window A rectangular area of the screen for viewing information. HP CDE allows you to create several types of windows on the screen. Each window is a separate computing environment in which you may execute programs, edit text, display graphical images, etc *See also Workspace Manager.*

Window manager The HP CDE program that controls the size, placement, and operation of windows.

Working directory *See current working directory.*

Workspace What the screen becomes when you start HP CDE. Although you can hide the workspace under terminal windows or other graphic objects, you can never position anything behind the workspace. All windows and graphic objects appear stacked “on top of” the workspace *See also HP Common Desktop Environment, terminal window.*

Workspace manager The program that controls the size, placement, and operation of windows on the HP CDE Workspace. The Workspace Manager is a special Window Manager *See also Window Manager.*

Workstation A compact, graphics-oriented computer having high speed and high memory capacity. A workstation usually includes a keyboard, a monitor, and a system unit *See also node, disked workstation, diskless workstation.*

Numerics

- 802.3 network
 - Problem, 204
 - Solution, 204
- 802.3 twisted pair LAN connector, 29, 33

A

- all, 199
- Applications, FCC B, 218
- Audio connectors, 29, 31
- Audio electrical specifications, 31
- auto boot, 194
- Auto boot, setting, 194
- auto search, 194
- Auto search, setting, 194

B

- Bezel latch button, 98
- Bezel lock, 98
- boot, 174
- Boot console interface features, 167
- Boot console interface menu
 - Configuration, 169
 - Information, 170
 - Main, 167
 - Service, 171
- Boot console interface, accessing, 172
- Boot failures, dealing with, 207
- Boot path, mnemonic style notation, 179
- Bootable media, searching, 177
- Booting and loading the operating system
 - Problem, 204
 - Solution, 204
- Booting computer, 174
- Busy indicator, 69
- Button, TOC, 29

C

- Cables, SCSI, 84
- Care, CD-ROM, 49
- Cautions and warnings, 223
- CD drive, 50
 - Installing, 114
 - Problem, 205
 - Removing, 120
 - Solution, 205
- CD drive, controls and features, 51
- CD drive, operating, 50
- CD drive, verifying, 61
- CD-ROM drive, 28
- CD-ROM media, 49
- CD-ROM, care, 49
- CD-ROM, loading and unloading, 52
- CD-ROM, mounting and unmounting, 55
- Common
 - Problems, 203
 - Solutions, 203
- Computer, booting, 174
- Computer, resetting, 178
- Configuring floppy driver, 62, 78
- Conformity, declaration of, 217
- Connector
 - 802.3 twisted pair LAN, 33
 - Audio, 29, 31
 - Fast Narrow Single-Ended SCSI, 29, 35
 - LAN (802.3 Twisted Pair), 29
 - Parallel (IEEE 1284), 29, 33
 - Power cord, 29, 35
 - RS-232C serial I/O, 29, 34
 - Ultra2 Wide Low-Voltage Differential SCSI, 29, 35
 - USB, 29, 32
- Console, changing to an external terminal, 190
- Controls, front panel, 26

- cpio, 78
- cstm, 214

D

- Declaration of conformity, 217
- Device files, using, 71
- disk, 61
- doscp, 78
- dosls, 78
- Driver, disk, 61

E

- Eject button, 69
- Electrical specifications, audio, 31
- Electrostatic discharge (ESD), 20
- EMI compliance, 29
- EMI gasket, 101
- Emissions regulations, 218
- Emissions regulations compliance, third party, 221
- ESD (electrostatic discharge), 20

F

- Fan
 - CPU area, 110
 - Hard disk drive area, 110
 - I/O card area, 110
- Fast Narrow Single-Ended SCSI, 24, 29, 30, 35, 86, 88
- fastboot, 197
- Fastboot mode
 - Displaying, 197
 - Setting, 197
- FCC B applications, 218
- floppy, 77, 78
- Floppy disk drive, 28
 - Busy indicator, 69
 - Controls and features, 69
 - Eject button, 69
 - Installing, 126

Operating, 69
Problem, 206
Removing, 133
Solution, 206
Verifying configuration, 77
Floppy diskette, 70
 Formatting, 74
 Inserting, 71
 Removing, 71
 Restoring files, 76
 Saving files, 75
 Transferring data, 75
Floppy diskette write-protect
 tab, 70
Floppy diskette, listing files, 76
Floppy driver, configuring, 62,
 78
Formatting, floppy diskette, 74
Front panel controls, 26
fwscsi, ipl device type, 177

G

Graphics path parameters, 182
graphics, optional, 23

H

Hard disk drive
 Configuring, 148
 Installing, 141
 Problem, 205
 Removing, 144
 Solution, 205
Hard disk drive area fan
 Removing, 111
 Replacing, 113
Hardware address, 179
Hardware configuration
 Left side panel of the system
 unit, 100
 System unit front panel, 98
 System unit power supply, 103
Headphones jack, 30

Host name, 43
HP hub, USB, 33
HP scroll mouse, USB, 33
HP VISUALIZE B1000/C3000
 Features, 23
Hub, HP USB devices, 33

I

I/O card
 Installing, 109
 Removing, 107
 Slot number and capabilities,
 106
I/O card slots, rear panel, 30
I/O, displaying the status of the
 system, 193
I/O, standard, 24
ide, ipl device type, 177
IEEE 1284, parallel connector,
 29
Ignition, instant, 42
Information, displaying system,
 199
Instant ignition, 40, 42
Instant Information, 46
Interface, user, 23
Internal storage devices, 24
Internet protocol (IP) address,
 41
Internet protocol address, 43
io, 193
ioscan, 61, 77, 90
IP address, 41
ipl device type
 fwscsi, 177
 ide, 177
 lan, 177
 pcin, 177
 scsi, 177

J

Japan, VCCI Class B ITE, 219

K

Keyboard, USB, 32
Korea RRL, 219

L

LAN station address, displaying,
 198
LAN station ID, 41
lan, ipl device type, 177
lanaddress, 198
Laser safety statement, 222
LCD fan failures and warnings,
 211
LCD information, 210
LCD symbols, 27
LED information, 222
Left side panel of the system
 unit, 100
Line input jack, 30
Line output jack, 30
Liquid crystal display (LCD), 27
Liquid Crystal Display (LCD)
 information, 210
Listing files, floppy diskette, 76
Loading and booting the
 operating system
 Problem, 204
 Solution, 204
Loading, CD-ROM, 52
Loop, security, 36

M

man, 78
Mask, subnetwork, 41
Media devices, removable, 28,
 114
Media, CD-ROM, 49
mediainit, 79
memory, 191
Memory card
 Installing, 153
 Removing, 157

Index

-
- Memory cards (DIMM cards), 153
 - Memory configuration, displaying, 191
 - Memory failures, 209
 - Memory information sample, 192
 - Memory, main, 24, 38
 - Microphone jack, 30
 - monitor, 181
 - Monitor configuration, displaying, 183
 - Monitor problems, troubleshooting, 163
 - Monitor type
 - Changing, 159
 - Displaying and setting, 181
 - Setting, 184
 - Setting at power on, 159, 188
 - Setting from boot console interface, 159
 - Setting using SAM, 160, 185
 - Monitor, troubleshooting, 189, 213
 - Monitors, 23, 39
 - Mounting, CD-ROM, 55
 - mstm, 214
 - N**
 - Network, standard, 24
 - O**
 - Operating system, 23
 - Operating system overview, 40
 - P**
 - Panel controls, front, 26
 - Parallel connector, 29
 - Parallel connector, IEEE 1284, 29
 - Parallel I/O connector, 33
 - Parallel port (IEEE 1284), 24
 - path, 179
 - Path type
 - alternate or alt, 179
 - console or con, 179
 - keyboard or key, 179
 - primary or pri, 179
 - Paths, displaying and setting, 179
 - PCI slots, 24
 - pcin, ipl device type, 177
 - Peripheral component interconnect (PCI) slots, 24
 - Power cord connector, 29
 - Power input, 30
 - Power supply, 103
 - Power switch, 27
 - Power, turning on, 45
 - Powering up the system
 - Problem, 203
 - Solution, 203
 - Powering up your system, 42
 - Problem
 - 802.3 network, 204
 - CD drive, 205
 - Floppy disk drive, 206
 - Hard disk drive, 205
 - Loading and booting the operating system, 204
 - Powering up the system, 203
 - Product description, 23
 - R**
 - Rear panel
 - Fast Narrow Single-Ended SCSI, 30
 - Headphones jack, 30
 - I/O card slots, 30
 - Line input jack, 30
 - Line output jack, 30
 - Microphone jack, 30
 - Power input, 30
 - Serial interface port, 30
 - Ultra2 Wide LVD SCSI, 30
 - USB ports, 30
 - Rear panel connectors, system unit, 30
 - Regulations, emissions, 218
 - Regulatory and safety information, special, 222
 - Removable media devices, 28, 114
 - reset, 178
 - Restoring files, floppy diskette, 76
 - RRL, Korea, 219
 - RS-232C serial I/O connector, 29, 34
 - S**
 - Safety and Regulatory information, special, 222
 - Safety interlock
 - Release pin, 101
 - Switch, 101
 - Safety statement, laser, 222
 - Saving files, floppy diskette, 75
 - Scroll mouse, HP, 33
 - SCSI
 - Fast Narrow Single-Ended, 29
 - Ultra2 Wide Low-Voltage Differential, 29
 - SCSI bus
 - Configuration constraints, 86
 - Device IDs, 90
 - Differences, 83
 - Fast Narrow Single-Ended, 83
 - Length constraints, 88
 - Restrictions, 84
 - Ultra2 Wide Low-Voltage Differential, 83
 - SCSI cables, 84
 - SCSI device IDs
 - assigning, 90
 - Fast Narrow Single-Ended, 91

Ultra2 Wide Low-Voltage
Differential, 92

SCSI ports
Connecting, 93

SCSI restrictions
cables, 84

SCSI terminators, 86

scsi, ipl device type, 177

search, 177

secure, 196

Security loop, 36

Security mode
Displaying, 196
Setting, 196

Serial interface port (RS-232C),
24

set_parms, 45

shutdown -q, 27

Solution
802.3 network, 204
CD drive, 205
Floppy disk drive, 206
Hard disk drive, 205
Loading and booting the
operating system, 204
Powering up the system, 203

Specifications, audio electrical,
31

Subnetwork mask, 41

Switch, power, 27

Symbols, LCD, 27

System information, displaying,
199

System LCD, 27

System overview, operating, 40

System unit fans, 110

System unit front panel, 98

System unit power supply, 103

System unit rear panel
connectors, 30

System verification tests,
running, 214

System, powering up, 42

T

tar, 78

Terminal, changing the console
to an external, 190

Terminators, SCSI, 86

Third party emissions
regulations compliance, 221

Time zone, 43

TOC button, 29

Transferring data, floppy
diskette, 75

U

Ultra2 Wide Low-Voltage
Differential SCSI, 24, 29,
30, 35, 86, 89

Universal serial bus (USB), 24

Unloading, CD-ROM, 54

Unmounting, CD-ROM, 58

USB
HP Hub, 33
HP scroll mouse, 33
Keyboard, 32

USB connectors, 29, 32

USB ports, 30

User interface, 23

V

VCCI Class B ITE (Japan), 219

Verifying, CD drive, 61

Video configuration statement,
special, 220

W

Warnings and cautions, 223

Workstation ACE for HP-UX
10.20 (June 1999), 40

Write-protect tab, floppy
diskette, 70

X

xstm, 214